

**Dot Matrix LCD Controller and Driver****Features**

- Internal LCD drivers
 - 16 common signal drivers
 - 40 segment signal drivers
 - (can be externally extended to 400 segments using NT3882A)
- Maximum display dimensions
 - 40 characters * 2 lines or
 - 80 characters * 1 line
- Interfaces with 4-bit or 8-bit MPU
- Versatile display functions provided on chip:
 - Display Clear, Cursor Home, Display ON/OFF, Cursor ON/OFF, Character Blinking, Cursor Shift, and Display Shift
- Three duty factors, selected by PROGRAM:
 - 1/8, 1/11, and 1/16
- Displays Data RAM (DD RAM): 80 X 8 bits (displays up to 80 characters)
- Character Generator RAM (CG RAM):
 - 64 X 8 bits for general data,
 - 8 5 X 8 programmable dot patterns, or
 - 4 5 X 10 programmable dot patterns
- Low voltage reset
- NOVATEK Identification code
- Bonding option for A-type and B-type waveform
- Character Generator ROM (CG ROM):
 - 3 kinds of CG ROM sizes:
 - 192 characters:
 - 160 5 X 8 dot patterns
 - 32 5 X 10 dot patterns
 - 240 characters:
 - 192 5 X 8 dot patterns
 - 48 5 X 10 dot patterns
 - 256 characters:
 - 192 5 X 8 dot patterns
 - 64 5 X 10 dot patterns
 - Custom CG ROM is also available
- Built-in power-on reset function
- Logic power supply: single +5V supply
- LCD driver power supply: $V_1 - V_5$ ($V_{DD}+0.3 - V_{DD}-13.5$)
- Three oscillator operations (Freq. = 250KHz - 270KHz):
 - Internal oscillation
 - Ceramic resonator
 - External clock
- CMOS Process
- Available in 80-pin QFP or in CHIP FORM

General Description

The NT3881D is a dot matrix LCD controller and driver LSI that can operate with either a 4-bit or an 8-bit microprocessor (MPU). NT3881D receives control character codes from the MPU, stores them in an internal RAM (up to 80 characters), transforms each character code into a 5 X 7, 5 X 8, or 5 X 10 dot matrix character pattern, and then displays the codes on the LCD panel. The built-in Character Generator ROM consists of 256 different character patterns.

The NT3881D also contains Character Generator RAM where the user can store 8 different character patterns at run time. These memory features make character display flexible. NT3881D also provides many display instructions to achieve versatile LCD display functions. The NT3881D is fabricated on a single LSI chip using the CMOS process, resulting in very low power requirements.

With several NT3882A driver ICs connected to the NT3881D, up to 80 characters can be displayed.

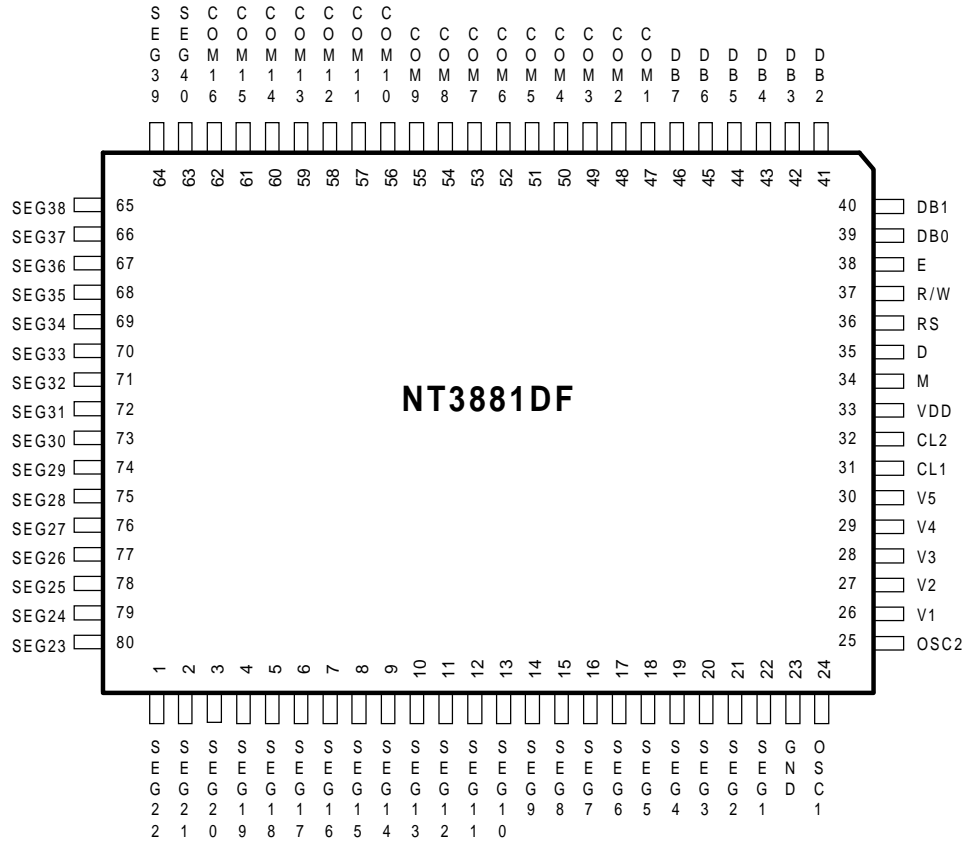
Pin Configuration

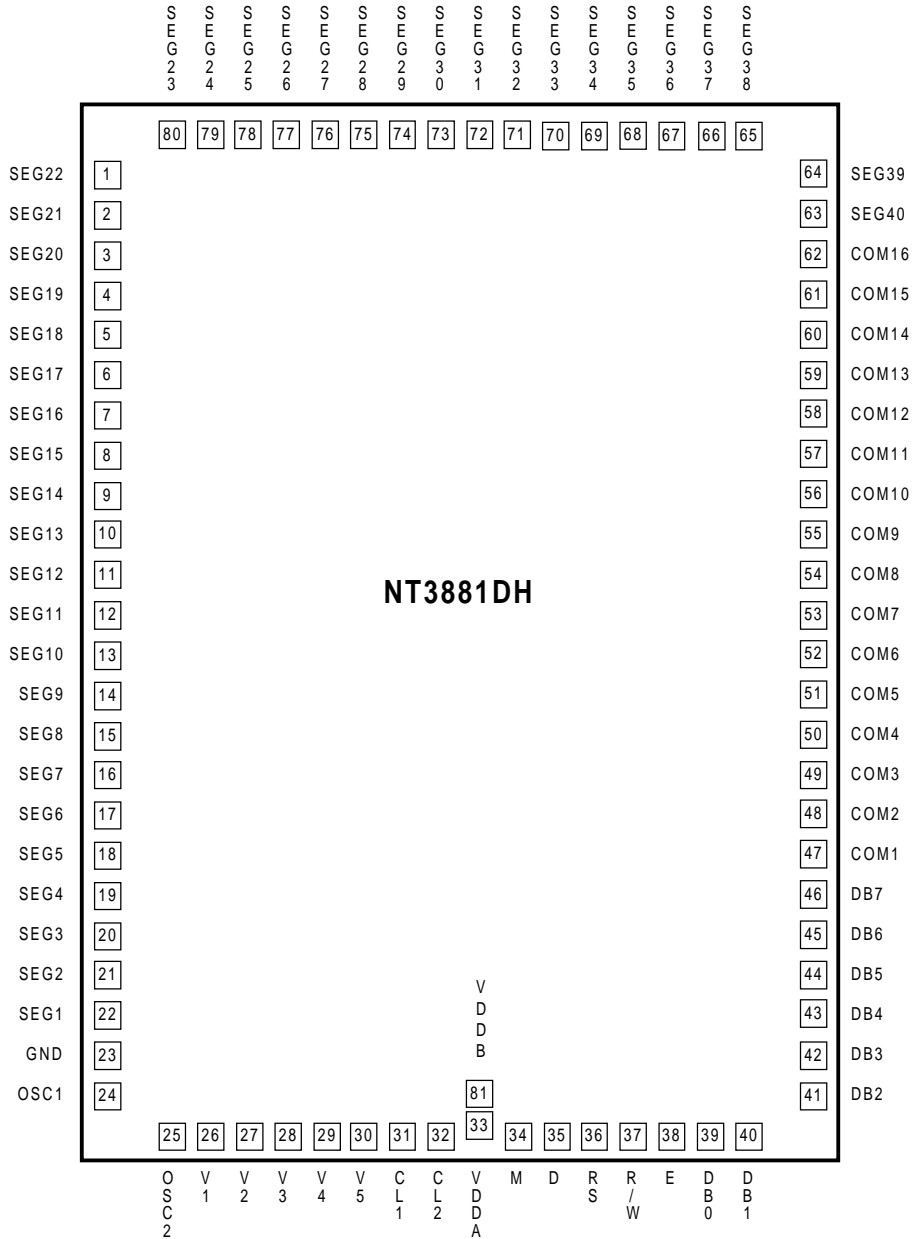
Pad Configuration

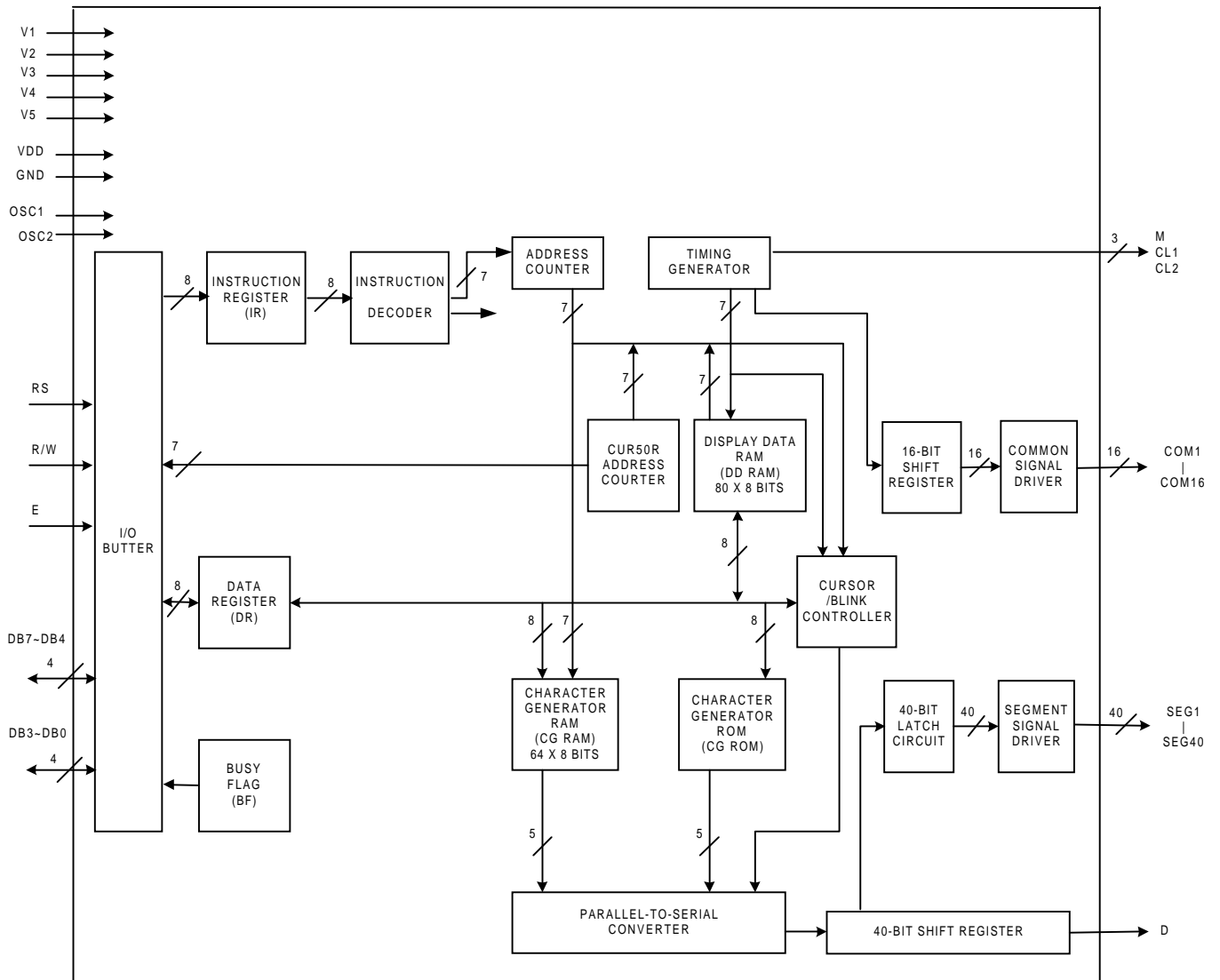
Block Diagram

Pin and Pad Descriptions

Pin and Pad No.	Designation	I/O	External Connection	Description
1 - 22	SEG22 - SEG1	O	LCD panel	Segment signal output pins
24, 25	OSC1, OSC2	O		Pins connected to resistor or ceramic filter for internal clock oscillation. For external clock operation, clock inputs to OSC1.
26 - 30	V ₁ - V ₅	P	Power supply	Power supply for LCD driver
31	CL1	O	NT3882A	Clock to latch serial data D sent to NT3882A.
32	CL2	O	NT3882A	Clock to shift serial data D
33 81	V _{DDA} V _{ddb}	P	Power supply	V _{DD} : +5V A-Type waveform: V _{DD} bond to V _{DDA} B-Type waveform: V _{DD} bond to V _{ddb}
23	GND	P	Power supply	GND: 0V
34	M	O	NT3882A	Switch signal to convert LCD drive waveform to AC
35	D	O	NT3882A	Character pattern data corresponding to each common signal is transmitted serially from this output. 0-Non selection, 1-selection.
36	RS	I	MPU	Register select signal 0: Instruction register (write) Busy flag, address counter (read) 1: Data register (write, read)
37	R/W	I	MPU	Read/Write control signal 0: Write 1: Read
38	E	I	MPU	Read/Write start signal
39 - 42	DB0 - DB3	I/O	MPU	Lower 4 tri-state bi-directional data bus for transmitting data between MPU and NT3881D. Not used during 4-bit operation.
43 - 46	DB4 - DB7	I/O	MPU	Higher 4 tri-state bi-directional data bus for transmitting data between MPU and NT3881D. DB7 is also used as busy flag.
47 - 62	COM1 - COM16	O	LCD panel	Common signal output pins
63 - 80	SEG40 - SEG23	O	LCD panel	Segment signal output pins

Functional Description

The NT3881D is a dot-matrix LCD controller and driver LSI. It operates with either a 4-bit or an 8-bit microprocessor (MPU). The NT3881D receives both instructions and data from the MPU. Some instructions set operation modes, such as the function mode, data entry mode, and display mode; as well as some control LCD display functions, such as clear display, restore display, shift display, and cursor. Other instructions include read and write both data and addresses. All instructions allow users convenient and powerful functions to control the LCD dot-matrix displays.

Data is written into and read from the Data Display RAM (DD RAM) or the Character Generator RAM (CG RAM). As display character codes, the data stored in the DD RAM decodes a set of dot-matrix character patterns that are built into the Character Generator ROM (CG ROM). The CG ROM, with many character patterns (up to 256 patterns), defines the character pattern fonts. The NT3881D regularly scans the character patterns through the segment drivers. The CG RAM stores character pattern fonts at run time if users intend to show character patterns that are not defined in the CG ROM. This feature makes character display flexible. Other unused bytes can be used as general-purpose data storage.

The LCD driver circuit consists of 16 common signal drivers and 40 segment signal drivers allowing a variety of application configurations to be implemented. Additionally, the user can extend display size by cascading the segment driver LSI NT3882A. The maximum display dimensions can be either 80 characters in a 1-line display or 40 characters in a 2-line display.

Character Generator ROM (CG ROM)

The character generator ROM generates LCD dot character patterns from the 8-bit character pattern codes. The NT3881D provides 3 CG ROM configurations:

1. 192 Characters:

The CG ROM contains 160 5 X 8 dot character patterns and 32 5 X 10 dot character patterns. An example is the NT3881D-01, in which the relation between the character codes and character patterns is shown in Table 1. The character codes from 00H to 0FH are used to get character patterns from the CG RAM. Character codes

from 10H to 1FH and from 80H to 9FH map to full character patterns. Character codes from E0H to FFH are assigned to generate 5 X 10 dot character patterns, and other codes are used to generate 5x8 dot character patterns.

2. 240 Characters:

The CG ROM contains 192 5 X 8 dot character patterns and 48 5 X 10 dot character patterns. An example of this type is the NT3881D-02, in which the relation between the character codes and character patterns is shown in Table 2.

The character codes from 00H to 0FH are used to get character patterns from the CG RAM. Character codes from 10H to 1FH and from E0H to FFH are assigned to generate 5 X 10 dot character patterns, and other codes to generate 5 X 8 dot character patterns. No null character pattern exists in this type. Note that the underlined cursor, displayed on the 8th duty may be obscure if the 8th row of a dot character pattern is coded. We recommend that users display the cursor in the blinking mode if they code 5x8 dot character patterns is their custom CG ROM.

3. 256 Characters:

The CG ROM contains 192 5 X 8 dot character patterns and 64 5 X 10 dot character patterns. No adequate example is presented here.

The only difference between this type and the just mentioned second type is that the character codes from 00H to 0FH get character patterns from the CG ROM rather than from the CG RAM. These character codes are assigned to generate 5 X 10 dot character patterns. In this application, the CG RAM would be employed as a general-purpose data storage.

Custom character patterns are available by mask-programming ROM. For convenience of character pattern development, NOVATEK has developed a user-friendly editor program for the NT3881D to help determine the character patterns users prefer. By executing the program on the computer, users can easily create and modify their character patterns. By transferring the resulting files generated by the program through a modem or some other communication method, the user and NOVATEK have established a reliable, fast link for programming the CG ROM.

Absolute Maximum Ratings*

Power Supply Voltage (V_{DD}) -0.3V to +0.7V
 Power Supply Voltage (V_1 to V_5)
 $V_{DD} -13.5V$ to $V_{DD}+0.3V$
 Input Voltage (V_i) -0.3V to $V_{DD} +0.3V$
 Operating Temperature (T_{OPR}) -20°C to +70°C
 Storage Temperature (T_{STG}) -55°C to +125°C

***Comments**

Stresses above those listed under "Absolute Maximum Ratings" may cause permanent damage to this device. These are stress ratings only. Functional operation of this device at these or any other conditions above those indicated in the operational sections of this specification is not implied or intended. Exposure to the absolute maximum rating conditions for extended periods may affect device reliability.

- All voltage values are referenced to GND = 0V
- V_1 to V_5 , must maintain $V_{DD} \geq V_1 \geq V_2 \geq V_3 \geq V_4 \geq V_5$.

DC Electrical Characteristics ($V_{DD} = 5.0V$, $GND = V_{EE} = 0V$, $T_A = 25^\circ C$)

Symbol	Parameter	Min.	Typ.	Max.	Unit	Conditions	Applicable Pin
V_{IH1}	"H" Level Input Voltage (1)	2.2	-	V_{DD}	V		DB0 - DB7, RS, R/W, E
V_{IL1}	"L" Level Input Voltage (1)	-0.3	-	0.8	V		
V_{IH2}	"H" Level Input Voltage (2)	$V_{DD} -1.0$	-	V_{DD}	V		OSC1
V_{IL2}	"L" Level Input Voltage (2)	GND	-	1.0	V		
V_{OH1}	"H" Level Output Voltage (1)	2.4	-	-	V	$I_{OH} = -0.25mA$	DB0 - DB7 (TTL)
V_{OL1}	"L" Level Output Voltage (1)	-	-	0.4	V	$I_{OL} = 1.2mA$	
V_{OH2}	"H" Level Output Voltage (2)	$0.9 V_{DD}$	-	-	V	$I_{OH} = -0.04mA$	CL1, CL2, M, D (CMOS)
V_{OL2}	"L" Level Output Voltage (2)	-	-	$0.1 V_{DD}$	V	$I_{OL} = 0.04mA$	
V_{COM}	Driver Voltage Descending (COM)	-	-	2.9	V	$I_D = 0.05mA$	COM1 - 16
V_{SEG}	Driver Voltage Descending (SEG)	-	-	3.8	V	$I_D = 0.05mA$	SEG1 - 40
I_{IL}	Input Leakage Current	-1	-	1	μA	$V_{IN} = 0$ to V_{DD}	
-IP	Pull-up MOS Current	50	125	250	μA	$V_{DD} = 5V$	RS, R/W, DB0-DB7
I_{OP}	Supply Current Power Supply Current	-	0.3	0.5	μA	Rf oscillation, from external clock $V_{DD} = 5V$, $f_{osc} = f_{CP} = 270KHz$	V_{DD}

DC Electrical Character (continued)

Symbol	Parameter	Min.	Typ.	Max.	Unit	Conditions	Applicable Pin
External Clock Operation							
f _{CP}	External Clock Operating Frequency	125	270	350	KHz		
t _{DUTY}	External Clock Duty Cycle	45	50	55	%		
t _{RCP}	External Clock Rise Time	0.1	-	0.5	μs		
t _{FCP}	External Clock Fall Time	0.1	-	0.5	μs		
Internal Clock Operation (RC Oscillator)							
f _{OSC}	Oscillator Frequency	190	270	350	KHz	R _f = 91KΩ ± 2%	
Internal Clock Operation (Ceramic Resonator Oscillator)							
f _{OSC}	Oscillator Frequency	245	250	255	KHz	Ceramic resonator	
V _{LCD1} V _{LCD2}	LCD Driving Voltage	4.6 3.0	-	V _{DD}	V	V _{DD} - V _S	

AC Characteristics

 Read Cycle (V_{DD} = 5.0V, GND = V_{EE} = 0V, T_A = 25°C)

Symbol	Parameter	Min.	Typ.	Max.	Unit	Conditions
t _{CYCE}	Enable Cycle Time	500	-	-	ns	Figure 1
t _{WHE}	Enable "H" Level Pulse Width	300	-	-	ns	Figure 1
t _{RE} , t _{FE}	Enable Rise/Fall Time	-	-	25	ns	Figure 1
t _{AS}	RS, R/W Setup Time	60 ¹	-	-	ns	Figure 1
		100 ²				
t _{AH}	RS, R/W Address Hold Time	10	-	-	ns	Figure 1
t _{RD}	Read Data Output Delay	-	-	190	ns	Figure 1
t _{DHR}	Read Data Hold Time	20	-	-	ns	Figure 1

AC Characteristics (continued)

 Write Cycle ($V_{DD} = 5.0V$, $GND = V_{EE} = 0V$, $T_A = 25^\circ C$)

Symbol	Parameter	Min.	Typ.	Max.	Unit	Conditions
t _{CYCE}	Enable Cycle Time	500	-	-	ns	Figure 2
t _{WHE}	Enable "H" Level Pulse Width	300	-	-	ns	Figure 2
t _{RE} , t _{FE}	Enable Rise/Fall Time	-	-	25	ns	Figure 2
t _{AS}	RS, R/W Setup Time	60 ¹	-	-	ns	Figure 2
		100 ²				
t _{AH}	RS, R/W Address Hold Time	10	-	-	ns	Figure 2
t _{DS}	Data Output Delay	100	-	-	ns	Figure 2
t _{DHR}	Data Hold Time	10	-	-	ns	Figure 2

 Notes: 1: 8-bit operation mode
 2: 4-bit operation mode

Timing Characteristics of Interface Signals with Segment Driver LSI NT3882A

 ($V_{DD} = 5V$, $GND = V_{EE} = 0V$, $T_A = 25^\circ C$)

Symbol	Parameter	Min.	Typ.	Max.	Unit	Conditions
t _{CWH}	Clock Pulse Width High	800	-	-	ns	Figure 3
t _{CWL}	Clock Pulse Width Low	800	-	-	ns	Figure 3
t _{SU}	Data Setup Time	300	-	-	ns	Figure 3
t _{DH}	Data Hold Time	300	-	-	ns	Figure 3
t _{CSU}	Clock Setup Time	500	-	-	ns	Figure 3
t _{DM}	M Delay Time	-1000	-	1000	ns	Figure 3

Power Supply Conditions Using Internal Reset Circuit

Symbol	Parameter	Min.	Typ.	Max.	Unit	Conditions
t _{RON}	Power Supply Rise Time	0.1	-	10	ms	Figure 4
t _{OFF}	Power Supply OFF Time	1	-	-	ms	Figure 4

Timing Waveforms
Read Operation

Figure 1. Bus Read Operation Sequence
(Reading out data from NT3881D to MPU)

Write Operation

Figure 2. Bus Write Operation Sequence
(Writing data from MPU to NT3881D)

Timing Waveforms (continued)
Interface Signals with Segment Driver LSI

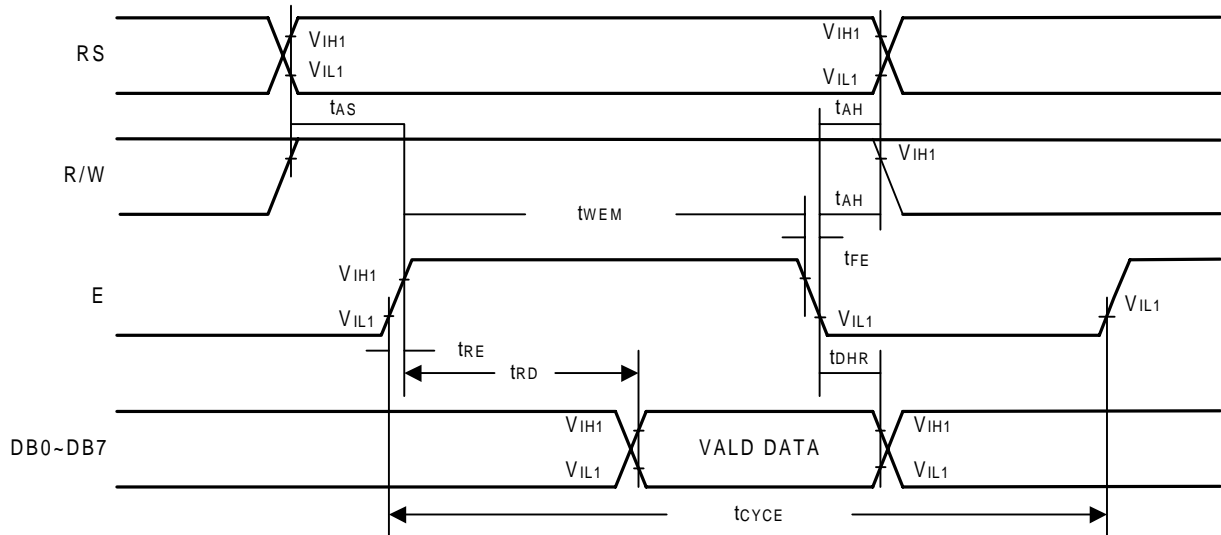
Figure 3. Sending Data to Segment Driver LSI NT3882A
Interface Signals with Segment Driver LSI (continued)

Figure 4. t_{OFF} stipulates the time of power OFF for instantaneous power supply to or when power supply repeats ON and OFF.

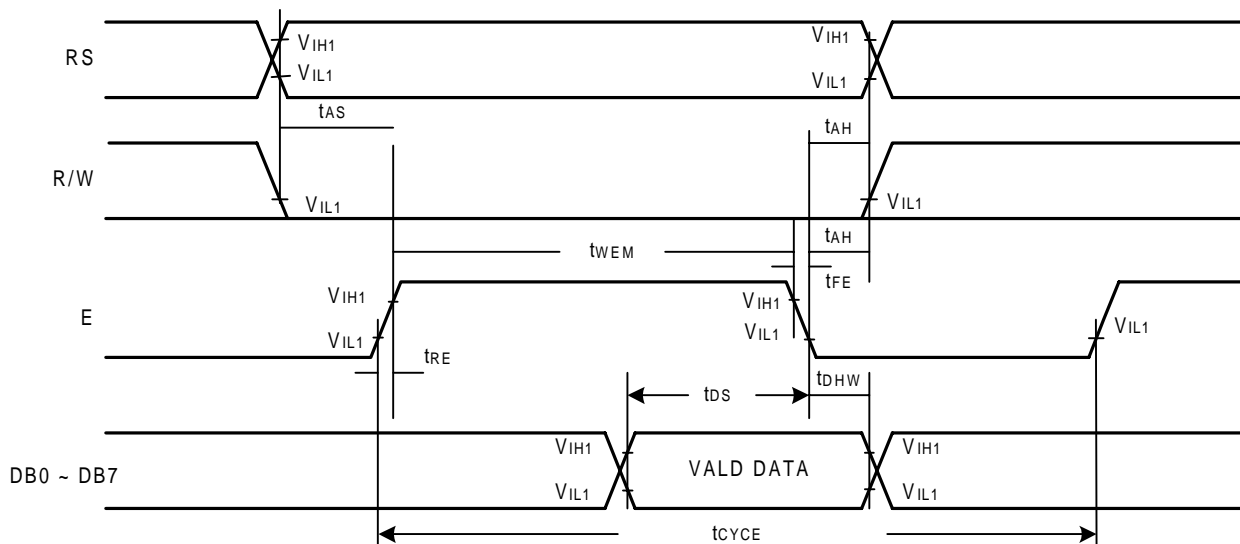
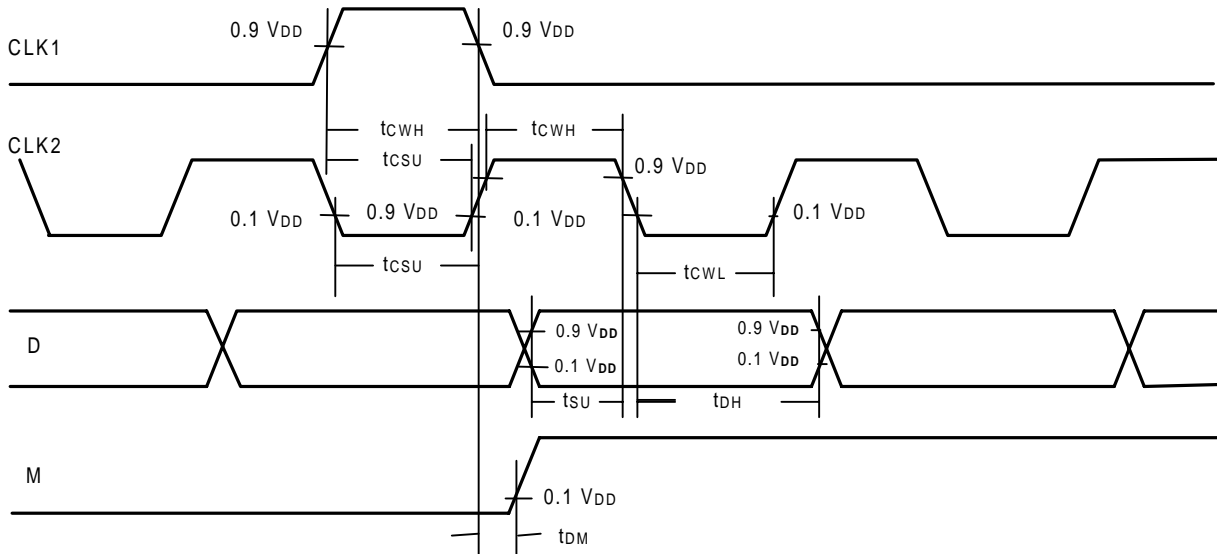
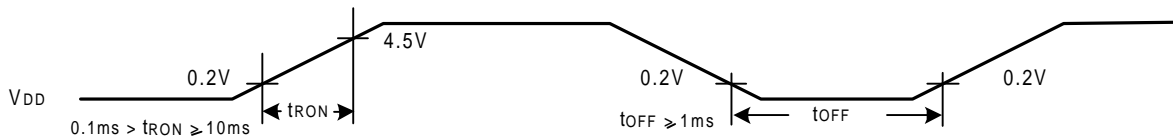
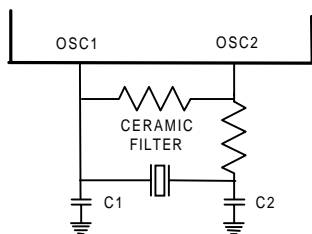
Note 1: The NT3881D has three clock options:

A. Internal Oscillator Operation (With Ceramic Filter)

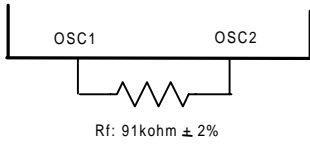
$R_d: 3.3K\Omega \pm 5\%$
 $C1 = C2: 680pF \pm 10\%$

$R_f: 1M\Omega \pm 10\%$

B. Internal Oscillator (With Rf Resistor)

Only Rf may be connected between OSC1 and OSC2.
The wire connection Rf must be as short as possible.

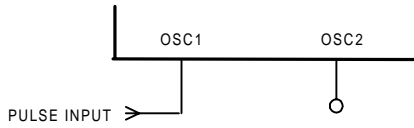
C. External Clock Operation

OSC1 and OSC2.

Note 2 : Input/Output Terminals:
A. Input Terminal

Applicable Terminal : E (No Pull Up MOS)

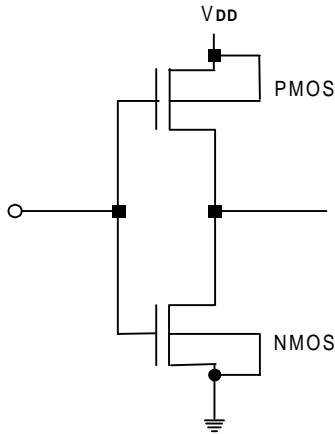

Applicable Terminals: RS, R/W (with Pull Up MOS)

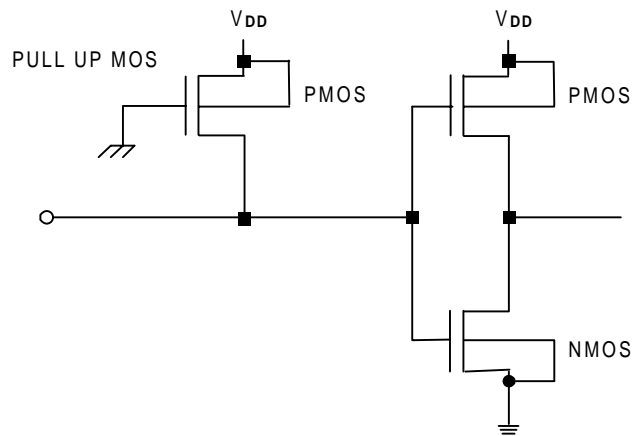

B. Output Terminal

Applicable Terminals: CL1, CL2, M, D

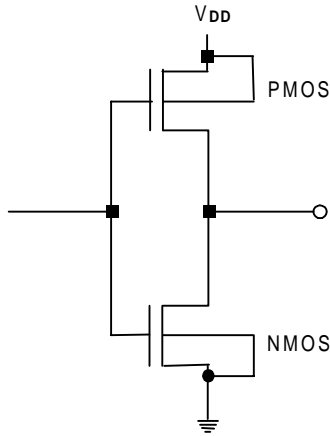
C. I/O Terminal

Applicable Terminals: DB0 to DB7

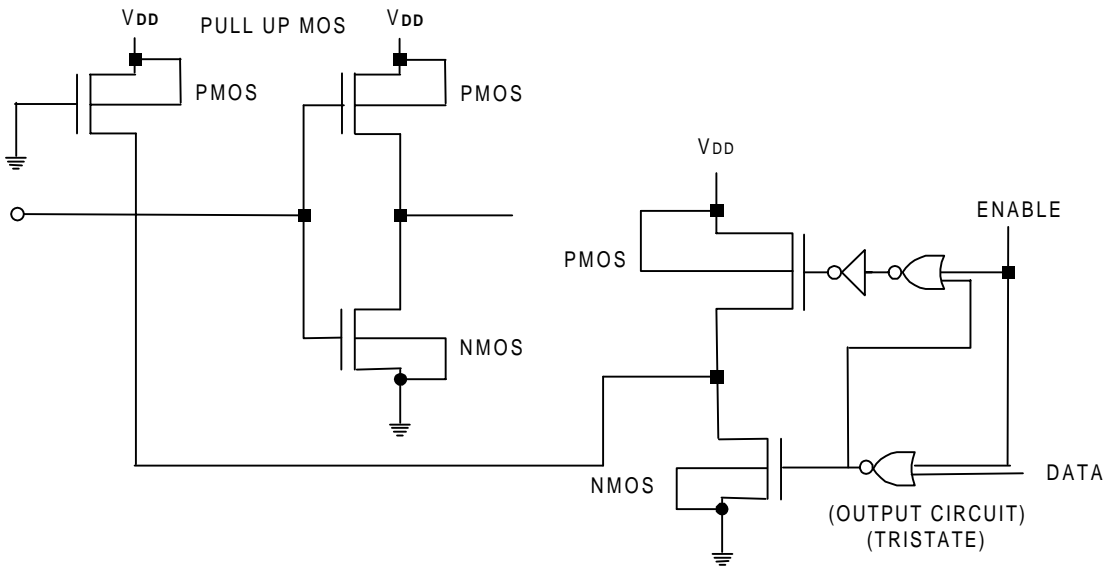

**Table 1. Correspondence between Character Codes and Character Patterns
(NOVATEK Standard NT3881D-01)**

		Higher 4-bit (D4 to D7) of Character Code (Hexadecimal)																
		0	1	2	3	4	5	6	7	8	9	A	B	C	D	E	F	
Lower 4-bit (D0 to D3) of Character Code (Hexadecimal)	0	CG RAM (1)			0	a	P	`	P				—	9	E	o	P	
	1	CG RAM (2)		!	1	A	Q	a	9				8	7	+	4	a	9
	2	CG RAM (3)		"	2	B	R	b	r				r	i	w	x	P	0
	3	CG RAM (4)		#	3	C	S	c	s				u	o	t	t	e	w
	4	CG RAM (5)		\$	4	D	T	d	t				\	i	t	t	P	0
	5	CG RAM (6)		%	5	E	U	e	u				.	o	*	u	o	ü
	6	CG RAM (7)		&	6	F	V	f	v				9	n	—	o	P	Z
	7	CG RAM (8)		'	7	G	W	g	w				7	+	x	7	9	n
	8	CG RAM (1)		(8	H	X	h	x				4	o	*	u	r	x
	9	CG RAM (2))	9	I	Y	i	y				o	q	u	u	—	y
	A	CG RAM (3)		*	#	J	Z	j	z				z	o	n	v	j	7
	B	CG RAM (4)		+	;	K	[k	[*	o	o	o	*	n
	C	CG RAM (5)		,	<	L]	l]				o	o	o	o	o	n
	D	CG RAM (6)		—	=	M	^	m	^				u	z	\	o	t	÷
	E	CG RAM (7)		.	>	N	~	n	~				o	o	o	o	n	
	F	CG RAM (8)		/	?	O	_	o	_				u	u	u	u	o	

**Table 2. Correspondence between Character Codes and Character Patterns
(NOVATEK Standard NT3881D-02)**

		Higher 4-bit (D4 to D7) of Character Code (Hexadecimal)															
		0	1	2	3	4	5	6	7	8	9	A	B	C	D	E	F
Lower 4-bit (D0 to D3) of Character Code (Hexadecimal)	0	CG RAM (1)	±		0	ø	P	'	P	9	è	à	'	r	M	ß	τ
	1	CG RAM (2)	≡	!	1	A	Q	a	9	0	æ	í	"	J	+	γ	υ
	2	CG RAM (3)	7	"	2	B	R	b	r	é	É	ó	◊	o	5	8	ζ
	3	CG RAM (4)	¿	#	3	C	S	c	s	à	á	ú	'	P	7	e	ψ
	4	CG RAM (5)	7	\$	4	D	T	d	t	ä	ö	ç	'	4	7	ζ	ω
	5	CG RAM (6)	7	%	5	E	U	e	u	à	á	É	é	†	Δ	η	ϕ
	6	CG RAM (7)	7	&	6	F	V	f	v	à	á	*	W	↓	Θ	Θ	≡
	7	CG RAM (8)	7	'	7	G	W	g	w	á	ú	R	x	→	Λ	Λ	≡
	8	CG RAM (1)	7	(8	H	X	h	x	é	ú	÷	÷	←	Σ	K	≡
	9	CG RAM (2)	7)	9	I	Y	i	y	é	ó	ì	ì	↑	Π	Λ	≡
	A	CG RAM (3)	×	*	#	J	Z	j	z	é	ó	á	z	↑	Σ	μ	≡
	B	CG RAM (4)	J	+	;	K	Γ	k	ç	í	R	á	×	L	↑	v	≡
	C	CG RAM (5)	≡	,	<	L	\	l	l	í	N	ó	×	J	Φ	ζ	□
	D	CG RAM (6)	o	-	=	M	J	m	¿	í	á	é	*	.	ψ	π	≡
	E	CG RAM (7)	è	.	>	N	^	n	~	á	ó	ó	↑	Θ	Ω	p	≡
	F	CG RAM (8)	è	/	?	O	_	o	Δ	á	ç	ó	↑	Θ	o	o	≡

Instruction Set

Instruction	Code										Function	Execution time (max) (f _{osc} = 250KHz)	
	RS	RW	DB7	DB6	DB5	DB4	DB3	DB2	DB1	DB0			
Display Clear	0	0	0	0	0	0	0	0	0	0	1	Clear entire display area, restore display from shift, and load address counter with DD RAM address 00H.	1.64ms
Display/ Cursor Home	0	0	0	0	0	0	0	0	0	1	*	Restore display from shift and load address counter with DD RAM address 00H.	1.64ms
Entry Mode Set	0	0	0	0	0	0	0	0	1	I/D	S	Specify direction of cursor movement and display shift mode. This operation takes place after each data transfer (read/write).	40μs
Display ON/OFF	0	0	0	0	0	0	0	1	D	C	B	Specify activation of display (D) cursor (C) and blinking of character at cursor position (B).	40μs
Display/ Cursor Shift	0	0	0	0	0	0	1	S/C	R/L	*	*	Shift display or move cursor.	40μs
Function Set	0	0	0	0	1	DL	N	F	*	*	*	Set interface data length (DL), number of display line (N), and character font (F).	40μs
RAM Address Set	0	0	0	1	ACG						Load the address counter with a CG RAM address. Subsequent data access is for CG RAM data.	40μs	
DD RAM Address Set	0	0	1	ADD						Load the address counter with a DD RAM address. Subsequent data access is for DD RAM data.	40μs		
Busy Flag/ Address Counter Read	0	1	AC						Read Busy Flag (BF) and contents of Address Counter (AC).	40μs			
CG RAM/ DD RAM Data Write	1	0	Write data						Write data to CG RAM or DD RAM.	40μs			
CG RAM/ DD RAM Data Read	1	1	Read data						Read data from CG RAM or DD RAM.	40μs			
	I/D = 1 : Increment S = 1 : Display Shift On D = 1 : Display On C = 1 : Cursor Display On B = 1 : Cursor Blink On S/C = 1 : Shift Display R/L = 1 : Shift Right DL = 1 : 8-Bit N = 1 : Dual Line F = 1 : 5x10 dots BF = 1 : Internal Operation BF = 1 : Ready for Instruction										I/D = 0 : Decrement S/C = 0 : Move Cursor R/L = 0 : Shift Left DL = 0 : 4-Bit N = 0 : Signal Line F = 0 : 5x8 dots	DD RAM : Display Data RAM CG RAM : Character Generator RAM ACG : Character Generator RAM Address ADD : Display Data RAM Address AC : Address Counter	

Note 1: Symbol "*" signifies an insignificant bit (disregard).

Note 2: Correct input value for "N" is predetermined for each model.

Interface to LCD
(1) Character Font and Number of Lines

The NT3881D provides a 5 X 7 dot character font 1-line mode, a 5 X 10 dot character font 1-line mode and a 5 X 7 dot character font 2-line mode, as shown in the table below.

Three types of common signals are available as displayed in the table. The number of lines and the font type can be selected by the program.

Number of Lines	Character Font	Number of Common Signals	Duty Factor
1	5 X 7 dots + Cursor (or 5x8 dots)	8	1/8
1	5 X 10 dots + Cursor	11	1/11
2	5 X 7 dots + Cursor (or 5x8 dots)	16	1/16

(2) Connection to LCD

The following 4 LCD connection examples show the various combinations between characters and lines. NT3881D can directly drive the following combinations:

(a) 5 X 8 Font - 8 character X 1 line (1/8 duty cycle, 1/4 bias)

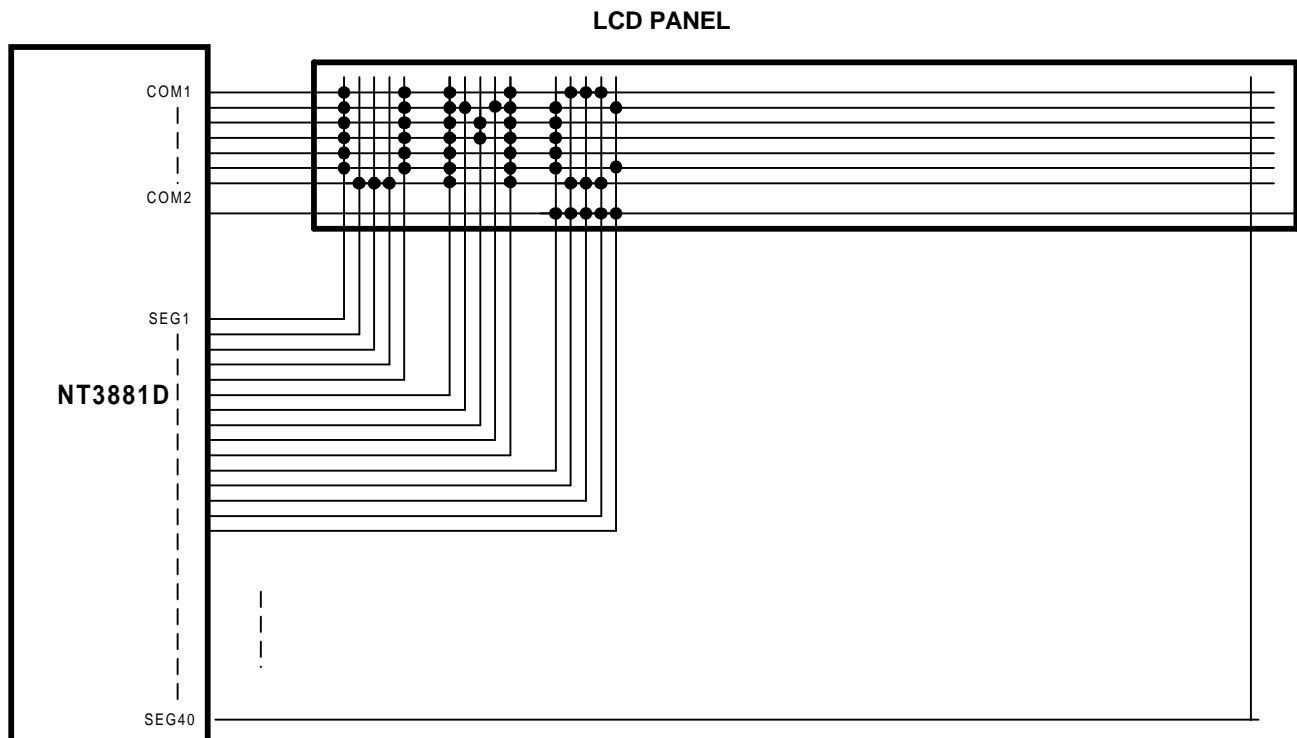

(b) 5 X 10 Font - 8 character X 1 line (1/11 duty cycle, 1/4 bias)

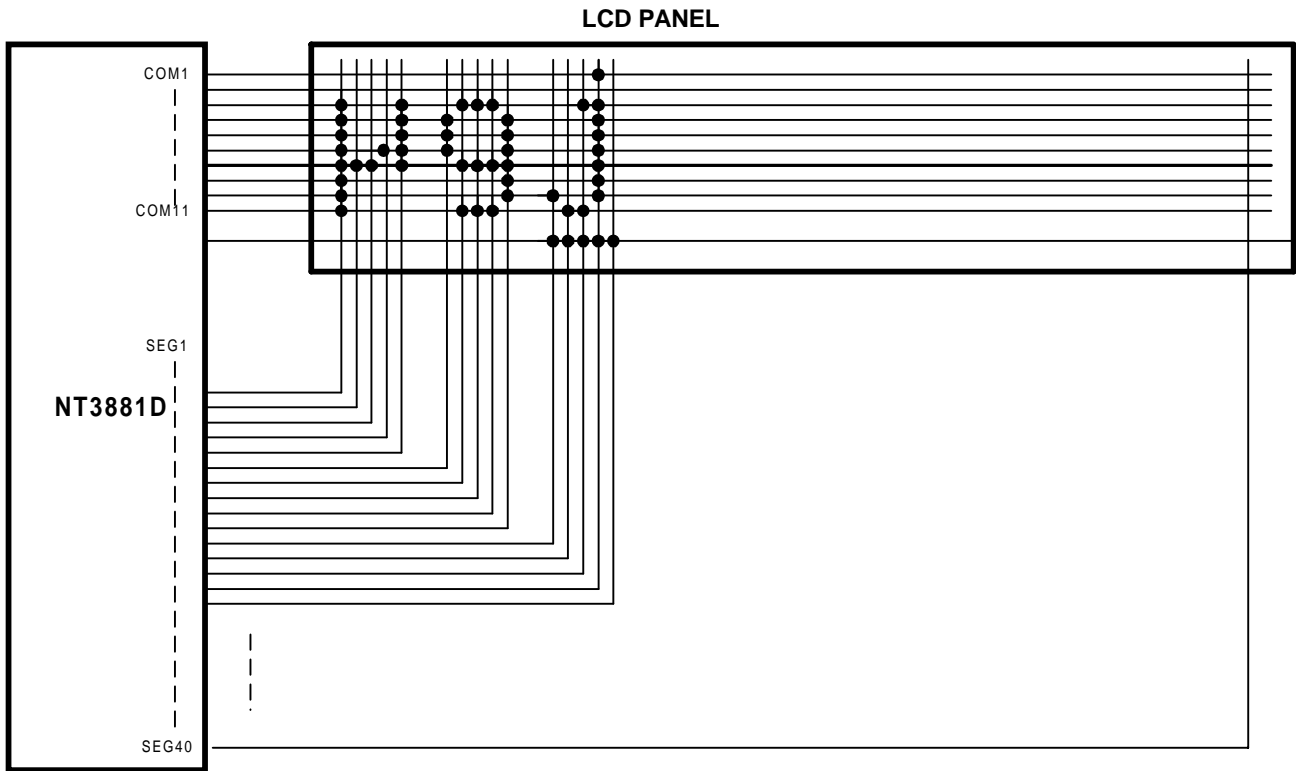

(c) 5 X 8 Font - 8 character X 2 lines (1/16 duty cycle, 1/5 bias)

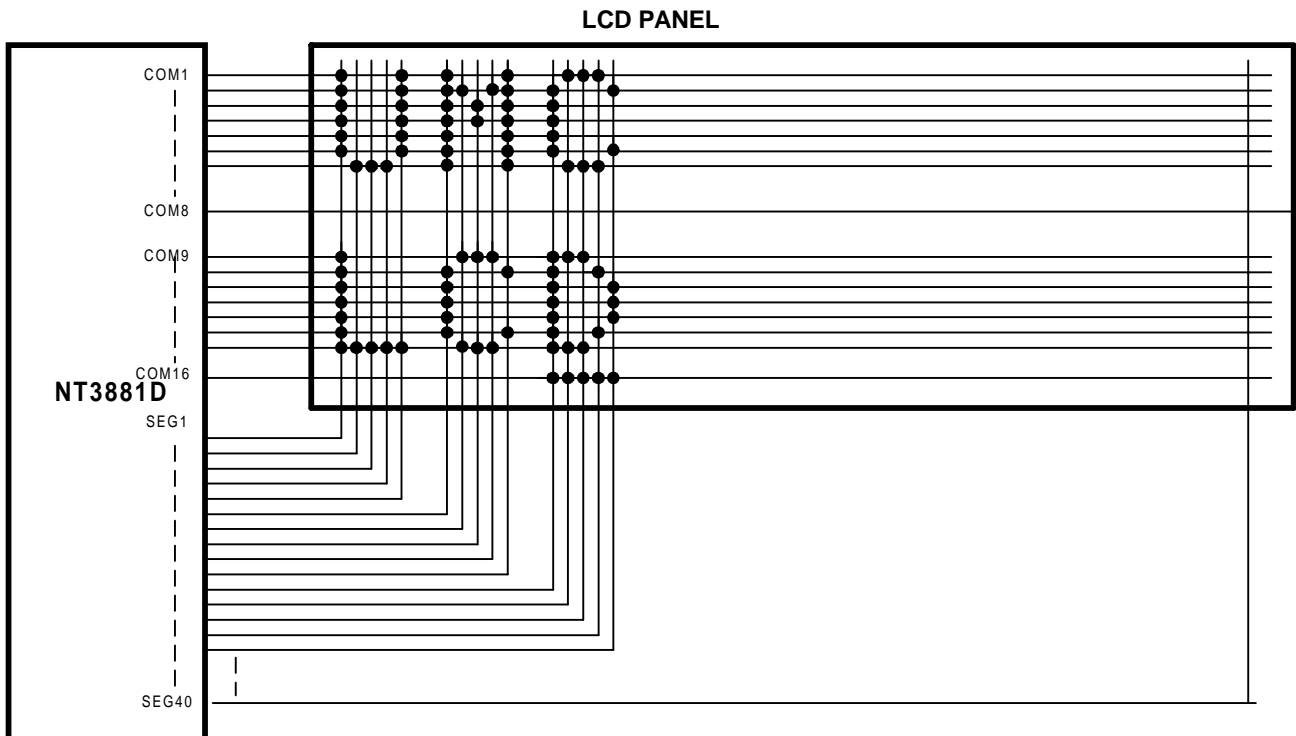

(d) 5 X 8 Font - 16 character X 1 line (1/16 duty cycle, 1/5 bias)

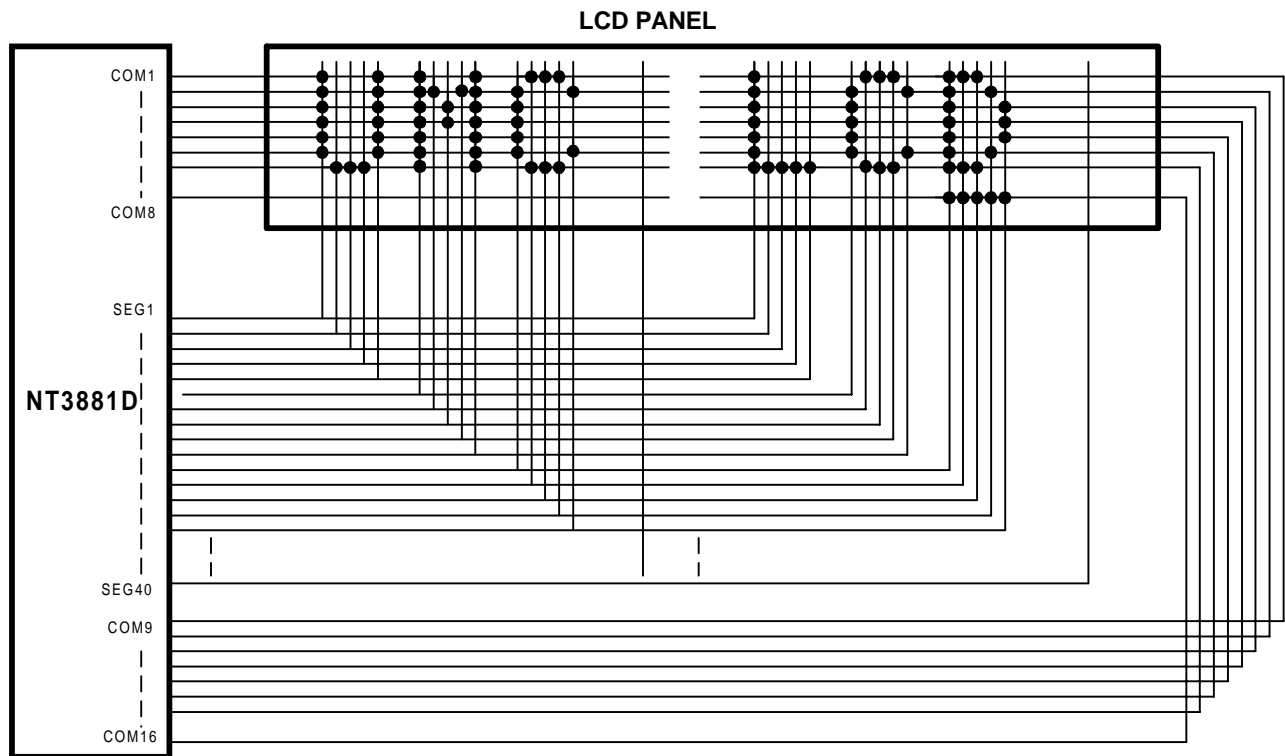

(3) Bias Power Connection

NT3881D provides 1/4 or 1/5 bias for various duty cycle applications. The power division voltage is described in the following table. The connection of NT3881D, power supply, and resistors are also shown as follows:

Power Division	1/8, 1/11 Duty Cycle - 1/4 Bias	1/16 Duty Cycle - 1/5 Bias
V ₁	$V_{DD} - 1/4 V_{LCD}$	$V_{DD} - 1/5 V_{LCD}$
V ₂	$V_{DD} - 1/2 V_{LCD}$	$V_{DD} - 2/5 V_{LCD}$
V ₃	$V_{DD} - 1/2 V_{LCD}$	$V_{DD} - 3/5 V_{LCD}$
V ₄	$V_{DD} - 3/4 V_{LCD}$	$V_{DD} - 4/5 V_{LCD}$
V ₅	$V_{DD} - V_{LCD}$	$V_{DD} - V_{LCD}$

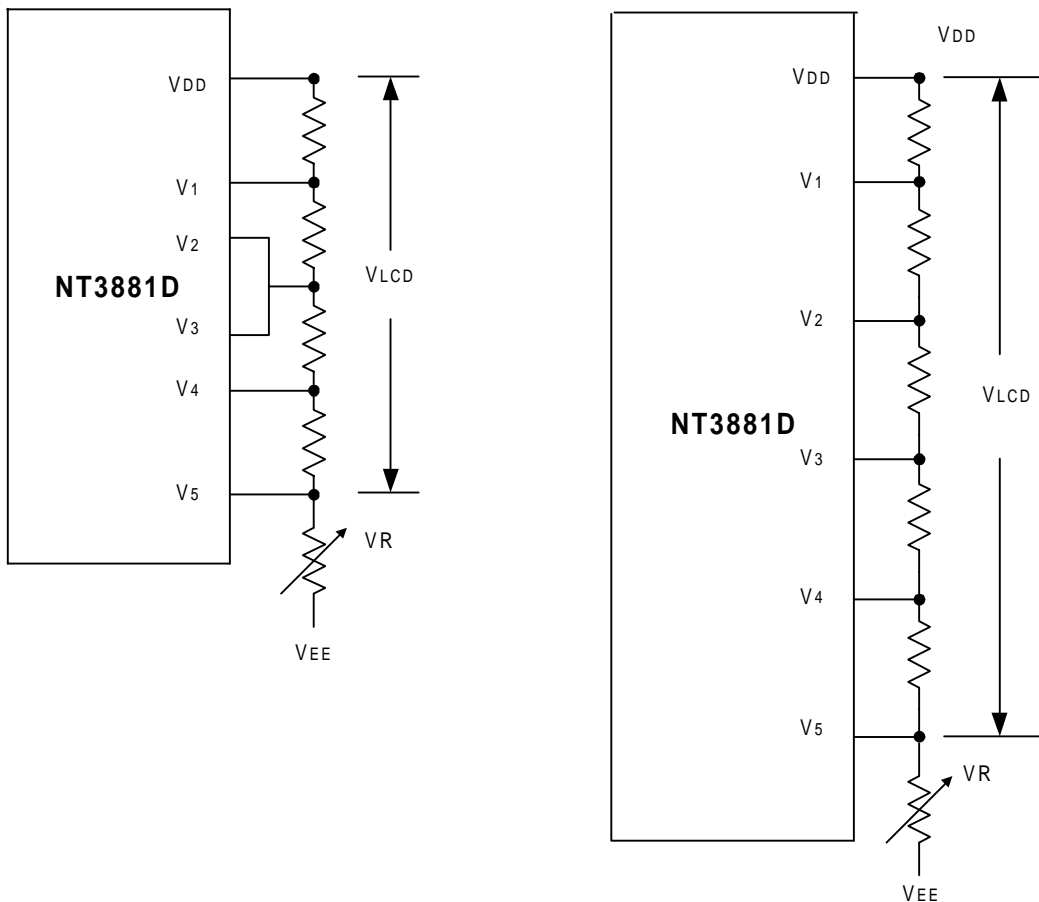

Note: The resistance value depends on the LCD panel size.

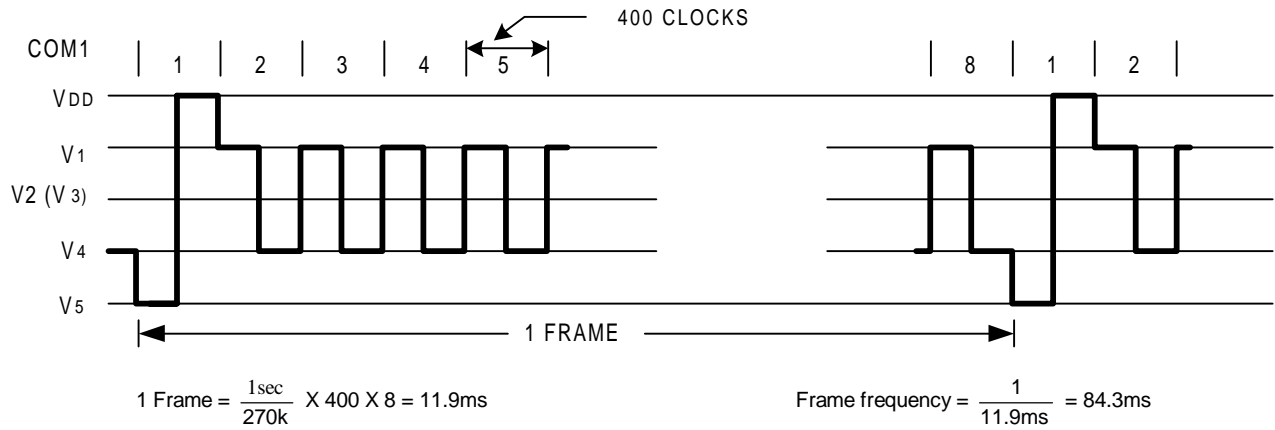
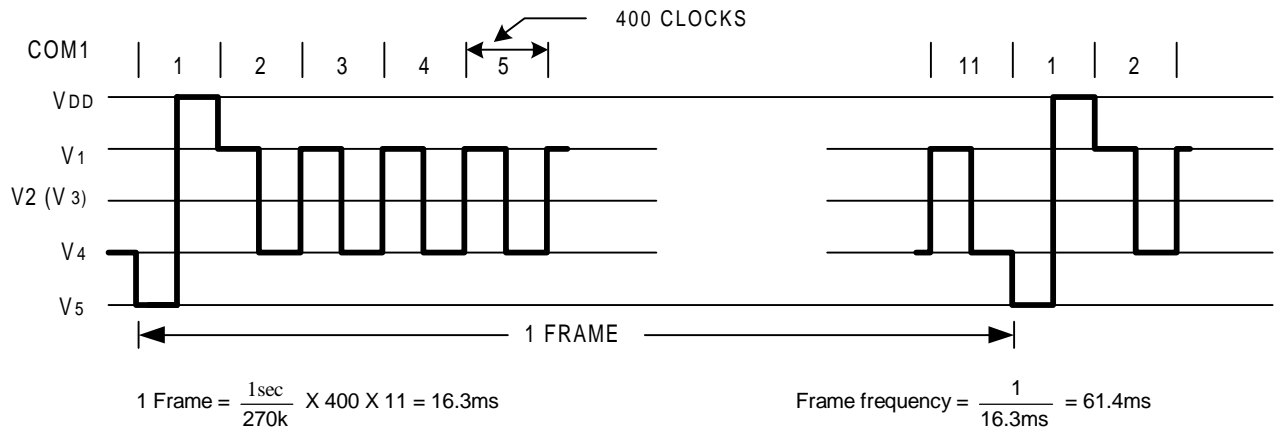
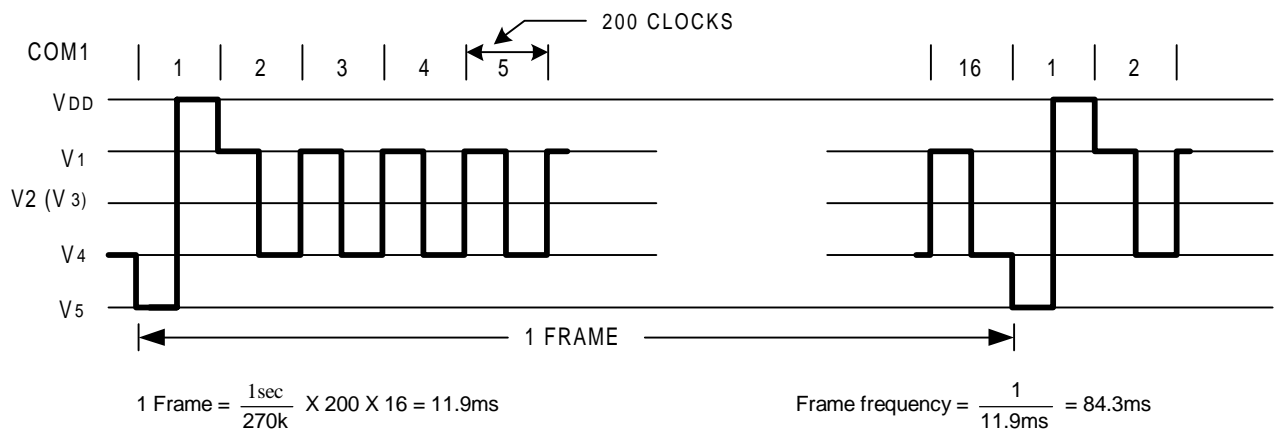
(4) LCD Waveform
A-type, 1/8 Duty Cycle, 1/4 Bias

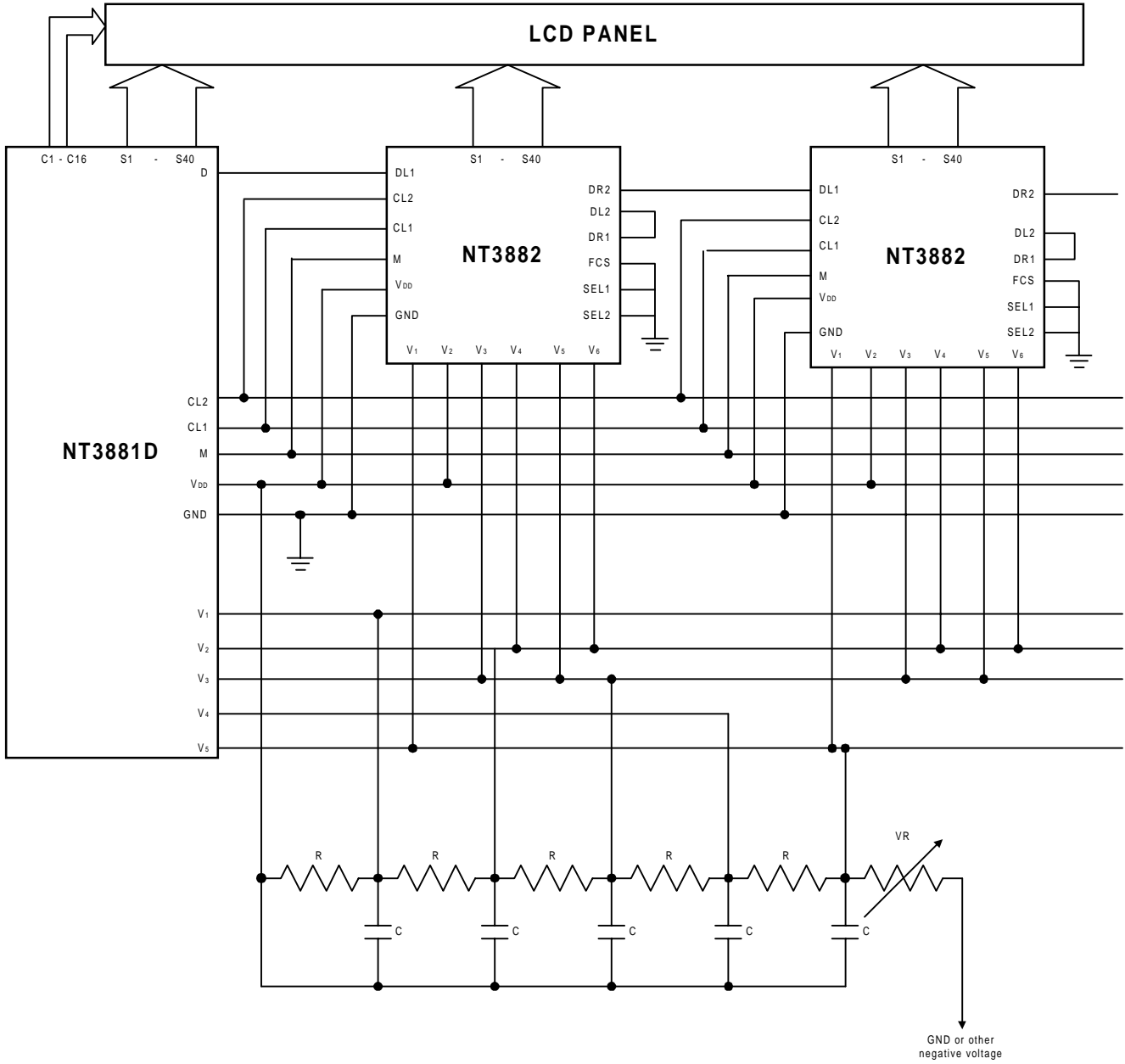
A-type, 1/11 Duty Cycle, 1/4 Bias

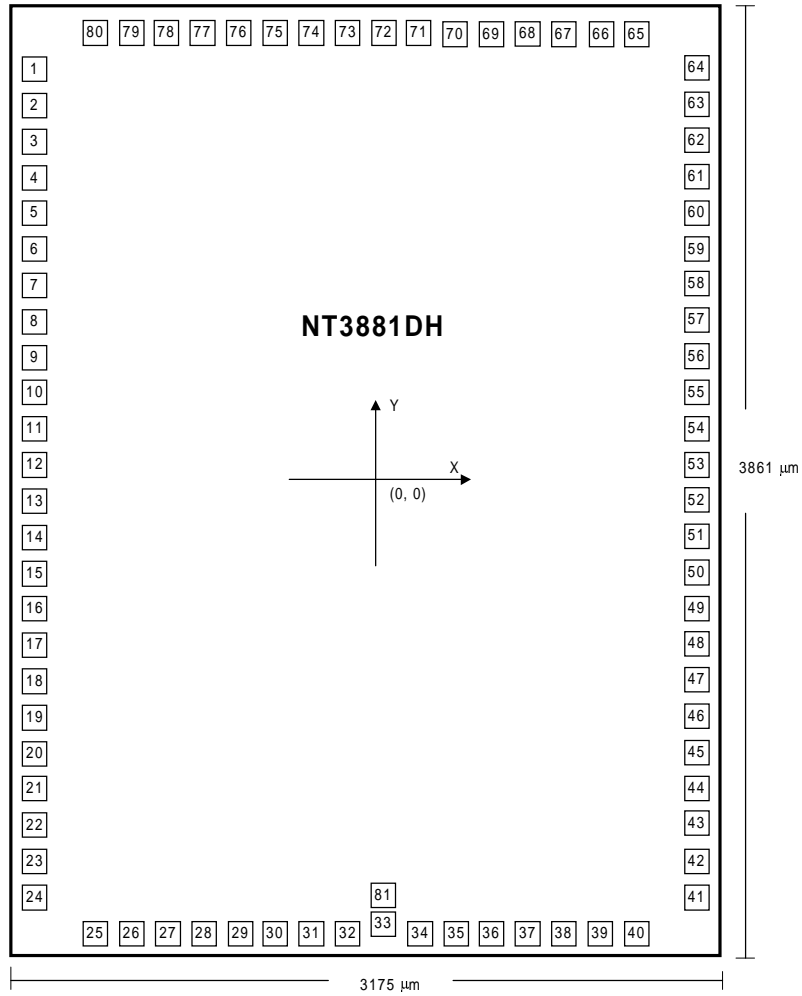
A-type, 1/16 Duty Cycle, 1/5 Bias

Application Circuit (for reference only)

Bonding Diagram

* Substrate Connect to V_{DD} or keep floating

* Pad window area: 120μm X 110μm

Bonding Dimensions

 unit: μm

Pad No.	Designation	X	Y	Pad No.	Designation	X	Y
1	SEG22	-1469	1743	41	DB2	1469	-1707
2	SEG21	-1469	1593	42	DB3	1469	-1557
3	SEG20	-1469	1443	43	DB4	1469	-1407
4	SEG19	-1469	1293	44	DB5	1469	-1257
5	SEG18	-1469	1143	45	DB6	1469	-1107
6	SEG17	-1469	993	46	DB7	1469	-957
7	SEG16	-1469	843	47	COM1	1469	-807
8	SEG15	-1469	693	48	COM2	1469	-657
9	SEG14	-1469	543	49	COM3	1469	-507
10	SEG13	-1469	393	50	COM4	1469	-357
11	SEG12	-1469	243	51	COM5	1469	-207
12	SEG11	-1469	93	52	COM6	1469	-57
13	SEG10	-1469	-57	53	COM7	1469	93
14	SEG9	-1469	-207	54	COM8	1469	243
15	SEG8	-1469	-357	55	COM9	1469	393
16	SEG7	-1469	-507	56	COM10	1469	543
17	SEG6	-1469	-657	57	COM11	1469	693
18	SEG5	-1469	-807	58	COM12	1469	843
19	SEG4	-1469	-957	59	COM13	1469	993
20	SEG3	-1469	-1107	60	COM14	1469	1143
21	SEG2	-1469	-1257	61	COM15	1469	1292
22	SEG1	-1469	-1407	62	COM16	1469	1443
23	GND	-1469	-1557	63	SEG40	1469	1593
24	OSC1	-1469	-1707	64	SEG39	1469	1743
25	OSC2	-1183	-1862	65	SEG38	1125	1862
26	V1	-1033	-1862	66	SEG37	975	1862
27	V2	-883	-1862	67	SEG36	825	1862
28	V3	-733	-1862	68	SEG35	675	1862
29	V4	-583	-1862	69	SEG34	525	1862
30	V5	-433	-1862	70	SEG33	375	1862
31	CL1	-283	-1862	71	SEG32	225	1862
32	CL2	-133	-1862	72	SEG31	75	1862
33	VDDA	76	-1691	73	SEG30	-75	1862
34	M	268	-1862	74	SEG29	-225	1862
35	D	418	-1862	75	SEG28	-375	1862
36	RS	568	-1862	76	SEG27	-525	1862
37	R/W	719	-1862	77	SEG26	-675	1862
38	E	870	-1862	78	SEG25	-825	1862
39	DB0	1020	-1862	79	SEG24	-975	1862
40	DB1	1170	-1862	80	SEG23	-1125	1862
				81	VDDB	76	-1816

Ordering Information

Part No.	Package	Remarks
NT3881DH-01	CHIP FORM	Refer to Table 1
NT3881DF-01	80L QFP/B-type waveform	Refer to Table 1
NT3881DH-02	CHIP FORM	Refer to Table 2
NT3881DF-02	80L QFP/B-type waveform	Refer to Table 2

Package Information
QFP 80L Outline Dimensions

unit: inches/mm

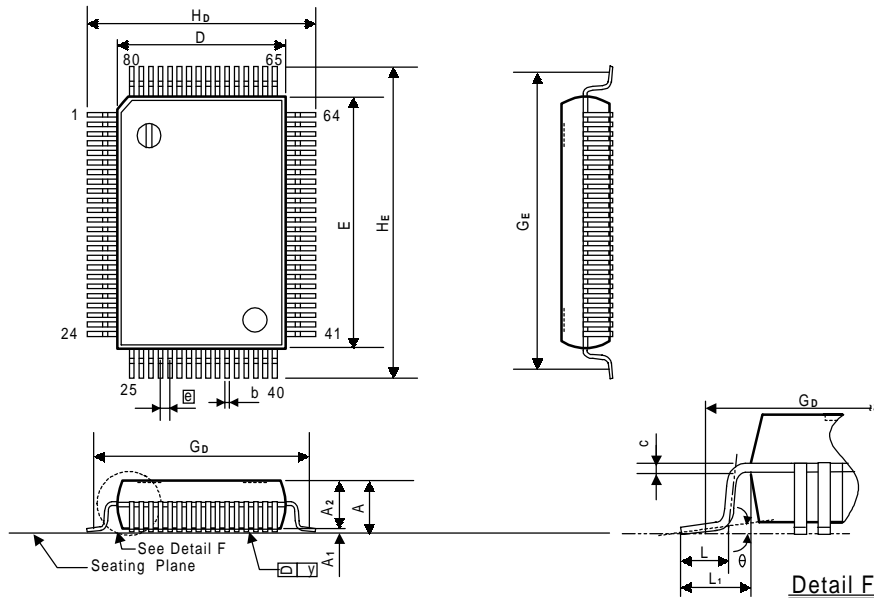

Symbol	Dimensions in inches	Dimensions in mm
A	0.130 Max.	3.30 Max.
A1	0.004 Min.	0.10 Min.
A2	0.112±0.005	2.85±0.13
b	0.014 +0.004 -0.002	0.35 +0.10 -0.05
c	0.006 +0.004 -0.002	0.15 +0.10 -0.05
D	0.551±0.005	14.00±0.13
E	0.787±0.005	20.00±0.13
e	0.031±0.006	0.80±0.15
G _D	0.693 NOM.	17.60 NOM.
G _E	0.929 NOM.	23.60 NOM.
H _D	0.740±0.012	18.80±0.31
H _E	0.976±0.012	24.79±0.31
L	0.047±0.008	1.19±0.20
L ₁	0.095±0.008	2.41±0.20
y	0.006 Max.	0.15 Max.
θ	0° ~ 12°	0° ~ 12°

Notes:

1. Dimensions D & E do not include resin fins.
2. Dimensions G_D & G_E are for PC Board surface mount pad pitch design reference only