

## ■ Features

- **5 x 8 dot matrix possible**
- **Low power operation support:**  
-- 2.7 to 5.5V
- **Wide range of LCD driver power**  
-- 3.0 to 7.0V
- **Support high speed serial interface**
- **Correspond to high speed MPU bus interface**  
-- 2 MHz (when  $V_{cc} = 5V$ )
- **80 x 9-bit display RAM (80 characters max.)**
- **19840-bit character generator ROM for a total of 496 character fonts(5 x 8 dot)**
- **64 x 8-bit character generator RAM**  
-- 8 character fonts (5 x 8 dot)
- **16-common x 80-segment liquid crystal display driver**
- **Programmable duty cycles**  
-- 1/8 for one line of 5 x 8 dots with cursor  
-- 1/16 for two lines of 5 x 8 dots & cursor
- **Wide range of instruction functions:**  
Display clear, cursor home, display on/off, cursor on/off, cursor shift, display shift
- **Automatic reset circuit that initializes the controller/driver after power on**
- **Internal oscillator with external resistors**
- **Low power consumption**
- **Bare Chip available (ST7070-XX-B)**

## ■ Description

The ST7070 dot-matrix liquid crystal display controller and driver LSI displays alphanumeric, Japanese kana characters, and symbols. It can be configured to drive a dot-matrix liquid crystal display under the control of a 4- or 8-bit microprocessor. With high speed serial interface(3-line SPI, 4-line SPI), the external MCU can control ST7070 directly. Since all the functions such as display RAM, character generator, and liquid crystal driver, required for driving a dot-matrix liquid crystal display are internally provided on one chip, a minimal system can be interfaced with this controller/driver.

The ST7070 has function partial compatibility with the HD44780, KS0066 and SED1278 that allows the user

to easily replace it with an ST7070. The ST7070 character generator ROM is extended to generate 496 5x8 dot character fonts for a total of 496 different character fonts. The low power supply (2.7V to 5.5V) of the ST7070 is suitable for any portable battery-driven product requiring low power dissipation.

The ST7070 LCD driver consists of 16 common signal drivers and 80 segment signal drivers which can extend display size by cascading segment driver ST7921. The maximum display size can be either 80 characters in 1-line display or 40 characters in 2-line display. A single ST7070 can display up to one 16-character line or two 16-character lines.

Product Name	Support Character
ST7070-0B	Standard code

<b>ST7070 Serial Specification Revision History</b>		
<b>Version</b>	<b>Date</b>	<b>Description</b>
0.1- Preliminary	2002/9/23	Preliminary version
0.1- Preliminary	2002/11/21	Add 3-line SPI interface
0.2- Preliminary	2002/12/20	1. N substrate change to P substrate. 2. Pad location modify.
0.3- Preliminary	2003/01/21	Modify "Supply Voltage for LCD Drive" Description I/O Pad Configuration
0.4- Preliminary	2003/2/18	Add Application circuit
0.5	2003/07/24	Modify the 4 bit interface Initializing flow by Instruction
0.6	2003/08/28	Change the font Table (0B)
0.7	2003/09/09	Add the DC Characteristics Note
0.8	2003/11/10	Modify the 4 bit interface Initializing flow by Instruction Add serial interface Initializing flow
1.0	2004/4/14	Add product name

■ Block Diagram

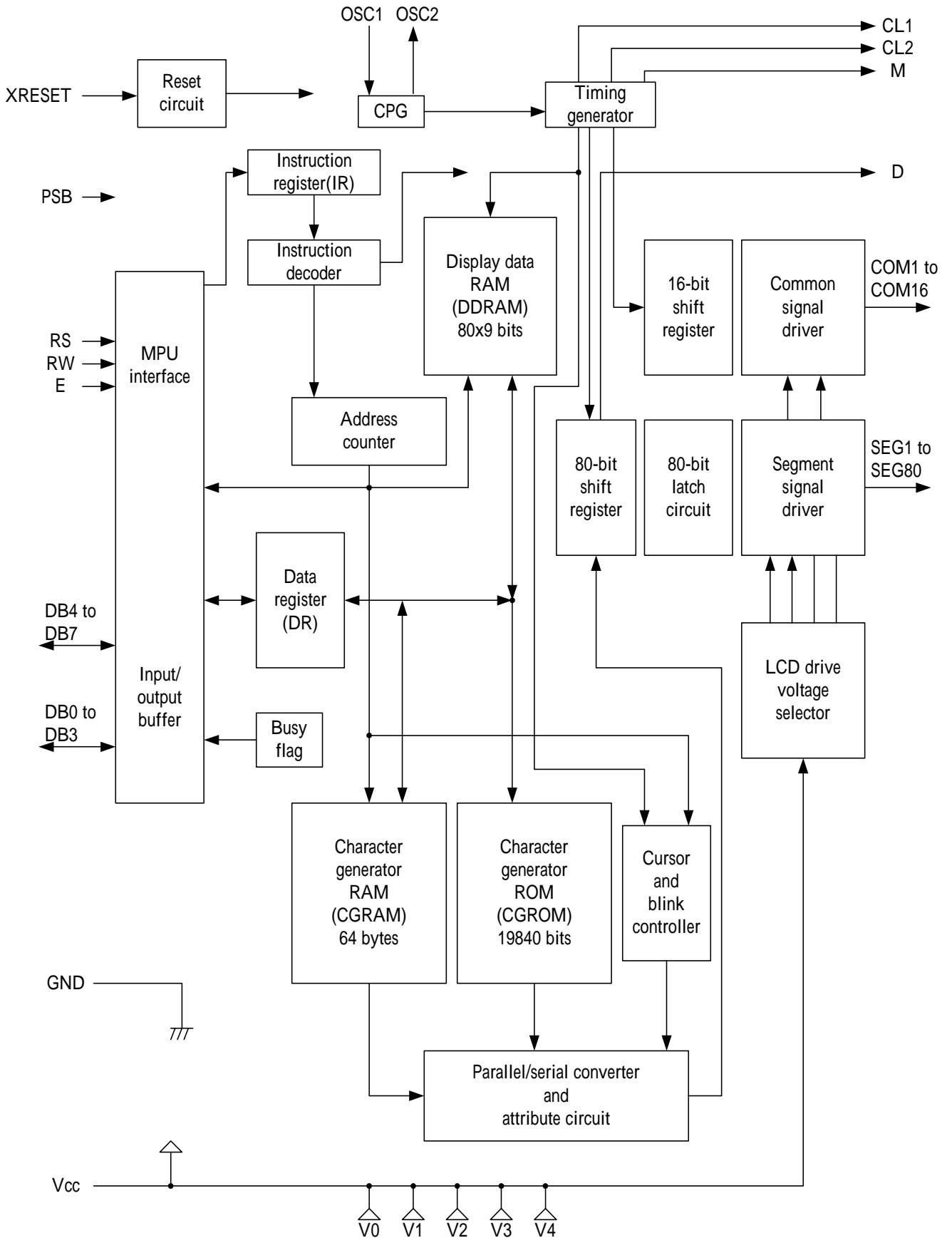

# Pad Arrangement

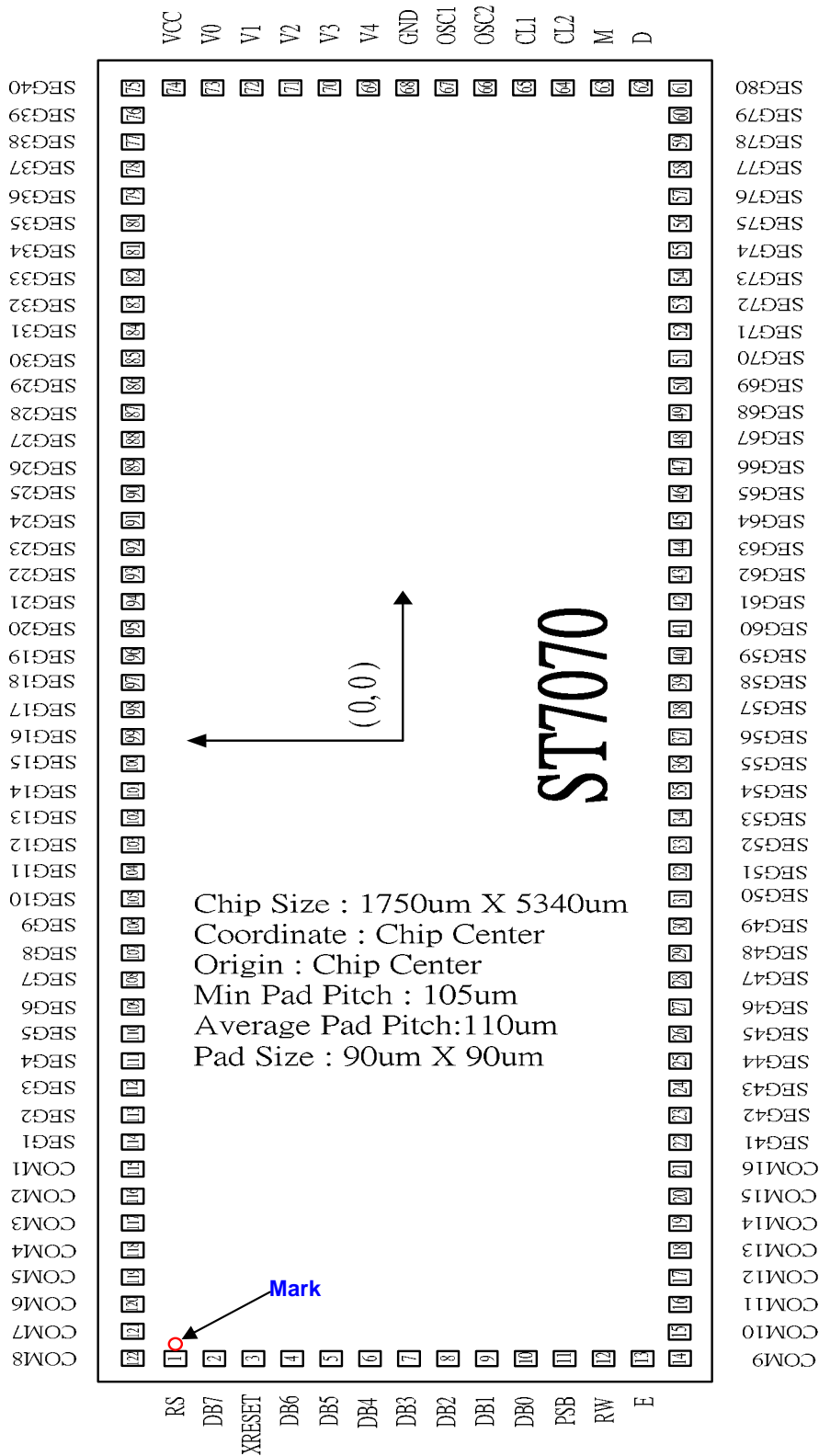

**Substrate must connect to "Vss".**

## Pad Configuration

Pad No.	Function	X	Y
001	RS	-2585	660
002	DB[7]	-2585	540
003	XRESET	-2585	430
004	DB[6]	-2585	320
005	DB[5]	-2585	210
006	DB[4]	-2585	105
007	DB[3]	-2585	0
008	DB[2]	-2585	-105
009	DB[1]	-2585	-210
010	DB[0]	-2585	-320
011	PSB	-2585	-430
012	RW	-2585	-540
013	E	-2585	-660
014	COM[9]	-2585	-790
015	COM[10]	-2445	-790
016	COM[11]	-2315	-790
017	COM[12]	-2195	-790
018	COM[13]	-2085	-790
019	COM[14]	-1975	-790
020	COM[15]	-1865	-790
021	COM[16]	-1755	-790
022	SEG[41]	-1645	-790
023	SEG[42]	-1535	-790
024	SEG[43]	-1425	-790
025	SEG[44]	-1315	-790
026	SEG[45]	-1208	-790
027	SEG[46]	-1102	-790
028	SEG[47]	-997	-790
029	SEG[48]	-892	-790
030	SEG[49]	-787	-790
031	SEG[50]	-682	-790
032	SEG[51]	-577	-790

Pad No.	Function	X	Y
033	SEG[52]	-472	-790
034	SEG[53]	-367	-790
035	SEG[54]	-262	-790
036	SEG[55]	-157	-790
037	SEG[56]	-52	-790
038	SEG[57]	52	-790
039	SEG[58]	157	-790
040	SEG[59]	262	-790
041	SEG[60]	367	-790
042	SEG[61]	472	-790
043	SEG[62]	577	-790
044	SEG[63]	682	-790
045	SEG[64]	787	-790
046	SEG[65]	892	-790
047	SEG[66]	997	-790
048	SEG[67]	1102	-790
049	SEG[68]	1207	-790
050	SEG[69]	1315	-790
051	SEG[70]	1425	-790
052	SEG[71]	1535	-790
053	SEG[72]	1645	-790
054	SEG[73]	1755	-790
055	SEG[74]	1865	-790
056	SEG[75]	1975	-790
057	SEG[76]	2085	-790
058	SEG[77]	2195	-790
059	SEG[78]	2315	-790
060	SEG[79]	2445	-790
061	SEG[80]	2585	-790
062	D	2585	-660
063	M	2585	-540
064	CL2	2585	-430

Pad No.	Function	X	Y
065	CL1	2585	-320
066	OSC2	2585	-210
067	OSC1	2585	-105
068	VSS	2585	0
069	V4	2585	105
070	V3	2585	210
071	V2	2585	320
072	V1	2585	430
073	V0	2585	540
074	VDD	2585	660
075	SEG[40]	2585	790
076	SEG[39]	2445	790
077	SEG[38]	2315	790
078	SEG[37]	2195	790
079	SEG[36]	2085	790
080	SEG[35]	1975	790
081	SEG[34]	1865	790
082	SEG[33]	1755	790
083	SEG[32]	1645	790
084	SEG[31]	1535	790
085	SEG[30]	1425	790
086	SEG[29]	1315	790
087	SEG[28]	1207	790
088	SEG[27]	1102	790
089	SEG[26]	997	790
090	SEG[25]	892	790
091	SEG[24]	787	790
092	SEG[23]	682	790
093	SEG[22]	577	790
094	SEG[21]	472	790
095	SEG[20]	367	790
096	SEG[19]	262	790
097	SEG[18]	157	790

Pad No.	Function	X	Y
098	SEG[17]	52	790
099	SEG[16]	-52	790
100	SEG[15]	-157	790
101	SEG[14]	-262	790
102	SEG[13]	-367	790
103	SEG[12]	-472	790
104	SEG[11]	-577	790
105	SEG[10]	-682	790
106	SEG[9]	-787	790
107	SEG[8]	-892	790
108	SEG[7]	-997	790
109	SEG[6]	-1102	790
110	SEG[5]	-1208	790
111	SEG[4]	-1315	790
112	SEG[3]	-1425	790
113	SEG[2]	-1535	790
114	SEG[1]	-1645	790
115	COM[1]	-1755	790
116	COM[2]	-1865	790
117	COM[3]	-1975	790
118	COM[4]	-2085	790
119	COM[5]	-2195	790
120	COM[6]	-2315	790
121	COM[7]	-2445	790
122	COM[8]	-2585	790

■ Pin Function

Name	Number	I/O	Interfaced with	Function
RS	1	I	MPU	Select registers. 0: Instruction register (for write) Busy flag: address counter (for read) 1: Data register (for write and read) When serial interface select ,RS pull low , not floating.
R/W	1	I	MPU	Select read or write. 0: Write 1: Read When serial interface select ,R/W pull low, not floating.
E	1	I	MPU	Starts data read/write. When serial interface select ,E pull height , not floating.
XRESET	1	I	MPU	Hardware reset pin, Low active
PSB	1	I	MPU	Parallel /Serial selection. PSB: "1" →Parallel , "0" →Serial.
DB4 to DB7	4	I/O	MPU	Four high order bi-directional tristate data bus pins. Used for data transfer and receive between the MPU and the ST7070. DB7 can be used as a busy flag. <b>Serial:</b> DB7:data input pin for serial mode(SI) DB6:serial clock input for serial mode(SCL) DB5:chip select pin for serial mode(/CS) When serial interface select ,D4 pull height , not floating. 4bits mode : These pins are used during 4-bit operation.
DB0 to DB3	4	I/O	MPU	Four low order bi-directional tristate data bus pins. Used for data transfer and receive between the MPU and the ST7070. These pins are not used during 4-bit operation and serial interface , must pull height , not floating.
CL1	1	O	Extension driver	Clock to latch serial data D sent to the Extension driver
CL2	1	O	Extension driver	Clock to shift serial data D
M	1	O	Extension driver	Switch signal for converting the liquid crystal drive waveform to AC
D	1	O	Extension driver	Character pattern data corresponding to each segment signal
COM1 to COM16	16	O	LCD	Common signals that are not used are changed to non-selection waveform. COM9 to COM16 are non-selection waveforms at 1/8 duty factor and COM12 to COM16 are non-selection waveforms at 1/11 duty factor.
SEG1 to SEG80	80	O	LCD	Segment signals
V0 to V4	5	-	Power supply	Power supply for LCD drive V0 - Vss = 10 V (Max)
Vcc, GND	2	-	Power supply	Vcc: 2.7V to 5.5V, GND: 0V
OSC1, OSC2	2		Oscillation resistor clock	When crystal oscillation is performed, a resistor must be connected externally. When the pin input is an external clock, it must be input to OSC1.

Note:

1. V0 >= V1 >= V2 >= V3 >= V4 >= Vss must be maintained
2. Two clock options:

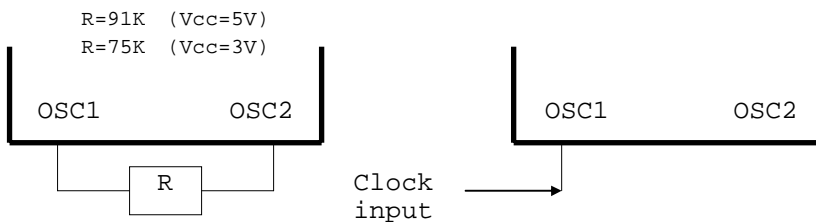

## Function Description

- **System Interface**

This chip has all two kinds of interface type with MPU : 4-bit bus and 8-bit bus. 4-bit bus or 8-bit bus is selected by DL bit in the instruction register.

During read or write operation, two 8-bit registers are used. One is data register (DR), the other is instruction register(IR).

The data register(DR) is used as temporary data storage place for being written into or read from DDRAM/CGRAM, target RAM is selected by RAM address setting instruction. Each internal operation, reading from or writing into RAM, is done automatically. So to speak, after MPU reads DR data, the data in the next DDRAM/CGRAM address is transferred into DR automatically. Also after MPU writes data to DR, the data in DR is transferred into DDRAM/CGRAM automatically.

The Instruction register(IR) is used only to store instruction code transferred from MPU. MPU cannot use it to read instruction data.

To select register, use RS input pin in 4-bit/8-bit bus mode.

RS	R/W	Operation
L	L	Instruction Write operation (MPU writes Instruction code into IR)
L	H	Read Busy Flag(DB7) and address counter (DB6 ~ DB0)
H	L	Data Write operation (MPU writes data into DR)
H	H	Data Read operation (MPU reads data from DR)

**Table 1. Various kinds of operations according to RS and R/W bits.**

- **Busy Flag (BF)**

When BF = "High", it indicates that the internal operation is being processed. So during this time the next instruction cannot be accepted. BF can be read, when RS = Low and R/W = High (Read Instruction Operation), through DB7 port. Before executing the next instruction, be sure that BF is not High.

- **Address Counter (AC)**

Address Counter(AC) stores DDRAM/CGRAM address, transferred from IR.

After writing into (reading from) DDRAM/CGRAM, AC is automatically increased (decreased) by 1.

When RS = "Low" and R/W = "High", AC can be read through DB6 ~ DB0 ports.



● **Display Data RAM (DDRAM)**

Display data RAM (DDRAM) stores display data represented in 9-bit character codes. Its extended capacity is 80 x 9 bits, or 80 characters. The area in display data RAM (DDRAM) that is not used for display can be used as general data RAM. See Figure 1 for the relationships between DDRAM addresses and positions on the liquid crystal display.

The DDRAM address ( $A_{DD}$ ) is set in the address counter (AC) as hexadecimal.

➤ **1-line display (N = 0) (Figure 2)**

When there are fewer than 80 display characters, the display begins at the head position. For example, if using only the ST7070, 8 characters are displayed. See Figure 3.

When the display shift operation is performed, the DDRAM address shifts. See Figure 3.

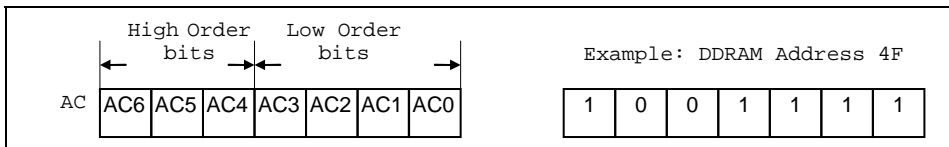

**Figure 1 DDRAM Address**

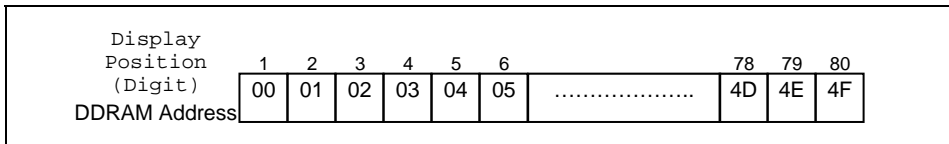

**Figure 2 1-Line Display**

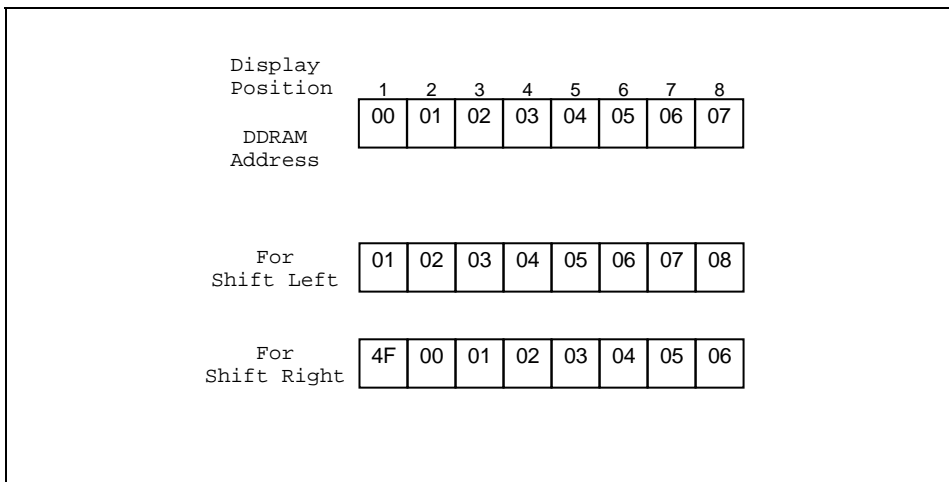

**Figure 3 1-Line by 8-Character Display Example**

➤ **2-line display (N = 1) (Figure 4)**

Display Position	1	2	3	4	5	6	.....	38	39	40
DDRAM Address (hexadecimal)	00	01	02	03	04	05	.....	25	26	27
	40	41	42	43	44	45	.....	65	66	67

**Figure 4 2-Line Display**

Case 1: When the number of display characters is less than 40 × 2 lines, the two lines are displayed from the head. Note that the first line end address and the second line start address are not consecutive. For example, when just the ST7070 is used, 16 characters × 2 lines are displayed. See Figure 5.

When display shift operation is performed, the DDRAM address shifts. See Figure 5.

Display Position	1	2	3	4	5	6	7	8	9	10	11	12	13	14	15	16
DDRAM Address	00	01	02	03	04	05	06	07	08	09	0A	0B	0C	0D	0E	0F
	40	41	42	43	44	45	46	47	48	49	4A	4B	4C	4D	4E	4F
For Shift Left	01	02	03	04	05	06	07	08	09	0A	0B	0C	0D	0E	0F	10
	41	42	43	44	45	46	47	48	49	4A	4B	4C	4D	4E	4F	50
For Shift Right	27	00	01	02	03	04	05	06	07	08	09	0A	0B	0C	0D	0E
	67	40	41	42	43	44	45	46	47	48	49	4A	4B	4C	4D	4E

**Figure 5 2-Line by 16-Character Display Example**

Case 2: For a 16-character × 2-line display, See Figure 5.

When display shift operation is performed, the DDRAM address shifts. See Figure 5.

- **Character Generator ROM (CGROM)**

The character generator ROM generates 5 x 8 dot character patterns from 9-bit character codes. It can generate 496 5 x 8 dot character patterns. User-defined character patterns are also available by mask-programmed ROM.

- **Character Generator RAM (CGRAM)**

In the character generator RAM, the user can rewrite character patterns by program. For 5 x 8 dots, eight character patterns can be written.

Write into DDRAM the character codes at the addresses shown as the left column of Table 4 to show the character patterns stored in CGRAM.

See Table 5 for the relationship between CGRAM addresses and data and display patterns. Areas that are not used for display can be used as general data RAM.

- **Timing Generation Circuit**

The timing generation circuit generates timing signals for the operation of internal circuits such as DDRAM, CGROM and CGRAM. RAM read timing for display and internal operation timing by MPU access are generated separately to avoid interfering with each other. Therefore, when writing data to DDRAM, for example, there will be no undesirable interference, such as flickering, in areas other than the display area.

- **LCD Driver Circuit**

LCD Driver circuit has 16 common and 80 segment signals for LCD driving. Data from CGRAM/CGROM is transferred to 80 bit segment latch serially, and then it is stored to 80 bit shift latch. When each common is selected by 16 bit common register, segment data also output through segment driver from 80 bit segment latch. In case of 1-line display mode, COM1 ~ COM8 have 1/8 duty, and in 2-line mode, COM1 ~ COM16 have 1/16 duty ratio.

- **Cursor Control Circuit**

It can generate the cursor in the cursor control circuit. The cursor or the blink appears in the digit at the display data RAM address set in the address counter.

Table 4 Correspondence between Character Codes and Character Patterns (Page 1)  
(b8=0)

ST7070-0B-01

b7-b4 b3-b0	0000	0001	0010	0011	0100	0101	0110	0111	1000	1001	1010	1011	1100	1101	1110	1111
0000	CG RAM (1)	0	1	2	3	4	5	6	7	8	9	A	B	C	D	E
0001	(2)	F	G	H	I	J	K	L	M	N	O	P	Q	R	S	T
0010	(3)	U	V	W	X	Y	Z	[	\	]	^	_	0	1	2	3
0011	(4)	4	5	6	7	8	9	A	B	C	D	E	F	G	H	I
0100	(5)	J	K	L	M	N	O	P	Q	R	S	T	U	V	W	X
0101	(6)	Y	Z	[	\	]	^	_	0	1	2	3	4	5	6	7
0110	(7)	8	9	A	B	C	D	E	F	G	H	I	J	K	L	M
0111	(8)	N	O	P	Q	R	S	T	U	V	W	X	Y	Z	[	\
1000	(1)	]	^	_	0	1	2	3	4	5	6	7	8	9	A	B
1001	(2)	C	D	E	F	G	H	I	J	K	L	M	N	O	P	Q
1010	(3)	R	S	T	U	V	W	X	Y	Z	[	\	]	^	_	0
1011	(4)	1	2	3	4	5	6	7	8	9	A	B	C	D	E	F
1100	(5)	G	H	I	J	K	L	M	N	O	P	Q	R	S	T	U
1101	(6)	V	W	X	Y	Z	[	\	]	^	_	0	1	2	3	4
1110	(7)	5	6	7	8	9	A	B	C	D	E	F	G	H	I	J
1111	(8)	K	L	M	N	O	P	Q	R	S	T	U	V	W	X	Y

Table 4 Correspondence between Character Codes and Character Patterns (Page 2)  
(b8=1)

ST7070-0B-02

b7-b4 b3-b0	0000	0001	0010	0011	0100	0101	0110	0111	1000	1001	1010	1011	1100	1101	1110	1111
0000	I	O	U	.	R	A	A	0	0	Y	B	R	0	T	1	
0001	F	Y	Y	0	0	E	0	*	A	0	0	0	0	0	0	0
0010	I	P	Y	E	'	0	0	'	N	A	0	E	N	0	U	0
0011	I	0	Y	0	0	N	0	'	N	0	0	0	0	0	0	0
0100	D	0	0	0	0	0	0	0	0	0	0	0	0	0	0	0
0101	0	0	0	0	0	0	0	0	0	0	0	0	0	0	0	0
0110	0	0	0	0	0	0	0	0	0	0	0	0	0	0	0	0
0111	0	0	0	0	0	0	0	0	0	0	0	0	0	0	0	0
1000	0	0	0	0	0	0	0	0	0	0	0	0	0	0	0	0
1001	0	0	0	0	0	0	0	0	0	0	0	0	0	0	0	0
1010	0	0	0	0	0	0	0	0	0	0	0	0	0	0	0	0
1011	X	0	0	0	0	0	0	0	0	0	0	0	0	0	0	0
1100	0	0	0	0	0	0	0	0	0	0	0	0	0	0	0	0
1101	0	0	0	0	0	0	0	0	0	0	0	0	0	0	0	0
1110	0	0	0	0	0	0	0	0	0	0	0	0	0	0	0	0
1111	0	0	0	0	0	0	0	0	0	0	0	0	0	0	0	0

Character Code (DDRAM Data)									CGRAM Address						Character Patterns (CGRAM Data)							
b8	b7	b6	b5	b4	b3	b2	b1	b0	b5	b4	b3	b2	b1	b0	b7	b6	b5	b4	b3	b2	b1	b0
0	0	0	0	0	-	0	0	0	0	0	0	0	0	0	-	-	-	1	1	1	1	1
						0	0	0				0	0	0								
						0	0	0				0	0	0								
						0	0	0				0	0	0								
						0	0	0				0	0	0								
						0	0	0				0	0	0								
						0	0	0				0	0	0								
						0	0	0				0	0	0								
						0	0	0				0	0	0								
0	0	0	0	0	-	0	0	1	0	0	1	0	0	0	-	-	-	1	1	1	1	0
						0	0	1				0	0	1								
						0	0	1				0	1	0								
						0	0	1				0	1	1								
						0	0	1				0	0	0								
						0	0	1				0	0	0								
						0	0	1				0	0	1								
						0	0	1				0	0	1								
						0	0	1				0	0	0								

**Table 5 Relationship between CGRAM Addresses, Character Codes (DDRAM) and Character patterns (CGRAM Data)**

Notes:

1. Character code bits 0 to 2 correspond to CGRAM address bits 3 to 5 (3 bits: 8 types).
  2. CGRAM address bits 0 to 2 designate the character pattern line position. The 8th line is the cursor position and its display is formed by a logical OR with the cursor. Maintain the 8th line data, corresponding to the cursor display position, at 0 as the cursor display. If the 8th line data is 1, 1 bits will light up the 8th line regardless of the cursor presence.
  3. Character pattern row positions correspond to CGRAM data bits 0 to 4 (bit 4 being at the left).
  4. As shown Table 5, CGRAM character patterns are selected when character code bits 4 to 7 are all 0. However, since character code bit 3 has no effect, the R display example above can be selected by either character code 00H or 08H.
  5. 1 for CGRAM data corresponds to display selection and 0 to non-selection.
- “-“: Indicates no effect.

## ■ Instructions

There are four categories of instructions that:

- Designate ST7070 functions, such as display format, data length, etc.
- Set internal RAM addresses
- Perform data transfer with internal RAM
- Others

Instruction Table:

Instruction	Instruction Code										Description	Description Time (270KHz)	
	RS	R/W	DB7	DB6	DB5	DB4	DB3	DB2	DB1	DB0			
<b>EXT = 0 or 1</b>													
Clear Display	0	0	0	0	0	0	0	0	0	0	1	Write "20H" to DDRAM, and set DDRAM address to "00H" from AC	1.52 ms
Return Home	0	0	0	0	0	0	0	0	0	1	x	Set DDRAM address to "00H" from AC and return cursor to its original position if shifted. The contents of DDRAM are not changed.	0 us
Display ON/OFF	0	0	0	0	0	0	0	1	D	C	P	D=1:entire display on C=1:cursor on P: font table page selection	37 us
Cursor or Display Shift	0	0	0	0	0	0	1	S/C	R/L	x	x	Set cursor moving and display shift control bit, and the direction, without changing DDRAM data.	37 us
Function Set	0	0	0	0	1	DL	N	EXT	x	x	x	DL: interface data is 8/4 bits N: number of line is 2/1	37 us
Read Busy flag and address	0	1	BF	AC6	AC5	AC4	AC3	AC2	AC1	AC0	AC0	Whether during internal operation or not can be known by reading BF. The contents of address counter can also be read.	0 us
Write data to RAM	1	0	D7	D6	D5	D4	D3	D2	D1	D0	D0	Write data into internal RAM (DDRAM/CGRAM)	37 us
Read data from RAM	1	1	D7	D6	D5	D4	D3	D2	D1	D0	D0	Read data from internal RAM (DDRAM/CGRAM)	37 us
<b>EXT = 0</b>													
Entry Mode Set	0	0	0	0	0	0	0	0	1	I/D	S	Sets cursor move direction and specifies display shift. These operations are performed during data write and read.	37 us
Set CGRAM address	0	0	0	1	AC5	AC4	AC3	AC2	AC1	AC0	AC0	Set CGRAM address in address counter	37 us
Set DDRAM address	0	0	1	AC6	AC5	AC4	AC3	AC2	AC1	AC0	AC0	Set DDRAM address in address counter	37 us

EXT = 1													
Bias resistor select	0	0	0	0	0	0	0	0	1	Rb1	Rb0	Used internal resistor only provide 1/5 bias mode . Rb[1:0]=00→External Resistor Rb[1:0]=01~11→Internal Resistor	37 us
COM, SEG direction select	0	0	0	1	0	0	C1	C2	S1	S2	C1 : com1~8→com8~1 C2 : com9~16→com16~9 S1 : seg1~40→seg40~1 S2 : seg41~80→seg80~41	37 us	
Set display data length	0	0	1	L6	L5	L4	L3	L2	L1	L0	To specify the number of data bytes(3SPI mode)	37 us	

Note:

Be sure the ST7070 is not in the busy state (BF = 0) before sending an instruction from the MPU to the ST7070. If an instruction is sent without checking the busy flag, the time between the first instruction and next instruction will take much longer than the instruction time itself. Refer to Instruction Table for the list of each instruction execution time.



## ■ Instruction Description

EXT=0 or 1

- **Clear Display**

	RS	RW	DB7	DB6	DB5	DB4	DB3	DB2	DB1	DB0
Code	0	0	0	0	0	0	0	0	0	1

Clear all the display data by writing "20H" (space code) to all DDRAM address, and set DDRAM address to "00H" into AC (address counter). Return cursor to the original status, namely, bring the cursor to the left edge on first line of the display. Make entry mode increment (I/D = "1").

- **Return Home**

	RS	RW	DB7	DB6	DB5	DB4	DB3	DB2	DB1	DB0
Code	0	0	0	0	0	0	0	0	1	x

Return Home is cursor return home instruction. Set DDRAM address to "00H" into the address counter. Return cursor to its original site and return display to its original status, if shifted. Contents of DDRAM does not change.

- **Display ON/OFF**

	RS	RW	DB7	DB6	DB5	DB4	DB3	DB2	DB1	DB0
Code	0	0	0	0	0	0	1	D	C	P

Control display/cursor/blink ON/OFF 1 bit register.

- **D : Display ON/OFF control bit**

When D = "High", entire display is turned on.

When D = "Low", display is turned off, but display data is remained in DDRAM.

- **C : Cursor ON/OFF control bit**

When C = "High", cursor is turned on.

When C = "Low", cursor is disappeared in current display, but I/D register remains its data.

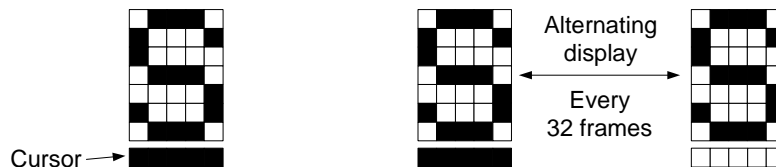

- **P : Font table selection bit**

When P = "Low", it select page 1 of font table.(set DDRAM data bit-8=0)

When P = "High", it select page 2 of font table(set DDRAM data bit-8=1)

● **Cursor or Display Shift**

	RS	RW	DB7	DB6	DB5	DB4	DB3	DB2	DB1	DB0
Code	0	0	0	0	0	1	S/C	R/L	x	x

Without writing or reading of display data, shift right/left cursor position or display. This instruction is used to correct or search display data. During 2-line mode display, cursor moves to the 2nd line after 40th digit of 1st line. Note that display shift is performed simultaneously in all the line. When displayed data is shifted repeatedly, each line shifted individually. When display shift is performed, the contents of address counter are not changed.

S/C	R/L	Description	AC Value
L	L	Shift cursor to the left	AC=AC-1
L	H	Shift cursor to the right	AC=AC+1
H	L	Shift display to the left. Cursor follows the display shift	AC=AC
H	H	Shift display to the right. Cursor follows the display shift	AC=AC

● **Function Set**

	RS	RW	DB7	DB6	DB5	DB4	DB3	DB2	DB1	DB0
Code	0	0	0	0	1	DL	N	EXT	x	x

➤ **DL : Interface data length control bit**

When DL = "High", it means 8-bit bus mode with MPU.

When DL = "Low", it means 4-bit bus mode with MPU. So to speak, DL is a signal to select 8-bit or 4-bit bus mode.

When 4-bit bus mode, it needs to transfer 4-bit data by two times.

➤ **N : Display line number control bit**

When N = "Low", it means 1-line display mode.

When N = "High", 2-line display mode is set.

➤ **EXT : Select basic or extended instruction set**

When EXT="L" the commands 'Entry Mode Set', 'Set CGRAM address' and 'Set DDRAM address' can be performed, when EXT="H" the commands 'Bias resistor select', 'COM, SEG direction select' and 'Set display data length' can be performed. Other command can be executed in both cases.

When EXT="L" : disable extension instruction

When EXT="H" : enable extension instruction

● **Read Busy Flag and Address**

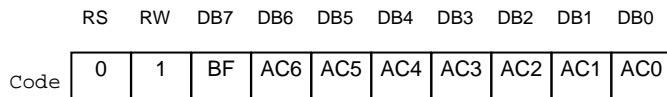

When BF = “High”, indicates that the internal operation is being processed. So during this time the next instruction cannot be accepted.

The address Counter (AC) stores DDRAM/CGRAM addresses, transferred from IR.

After writing into (reading from) DDRAM/CGRAM, AC is automatically increased (decreased) by 1.

● **Write Data to CGRAM or DDRAM**

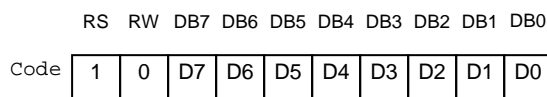

Write binary 8-bit data to DDRAM/CGRAM.

The selection of RAM from DDRAM, CGRAM, is set by the previous address set instruction

: DDRAM address set, CGRAM address set. RAM set instruction can also determine the AC direction to RAM. DDRAM data bit-8 is come from “P”(Display on/off instruction) register setting

After write operation, the address is automatically increased/decreased by 1, according to the entry mode.

● **Read Data from CGRAM or DDRAM**

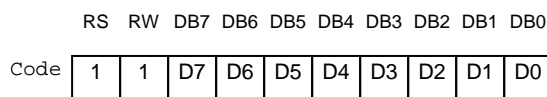

Read binary 8-bit data from DDRAM/CGRAM.

The selection of RAM is set by the previous address set instruction. If address set instruction of RAM is not performed before this instruction, the data that read first is invalid, because the direction of AC is not determined. If you read RAM data several times without RAM address set instruction before read operation, you can get correct RAM data from the second, but the first data would be incorrect, because there is no time margin to transfer RAM data.

In case of DDRAM read operation, cursor shift instruction plays the same role as DDRAM address set instruction : it also transfer RAM data to output data register. After read operation address counter is automatically increased/decreased by 1 according to the entry mode. After CGRAM read operation, display shift may not be executed correctly.

\* In case of RAM write operation, after this AC is increased/decreased by 1 like read operation. In this time, AC indicates the next address position, but you can read only the previous data by read instruction.

**EXT=0**

● **Entry Mode Set**

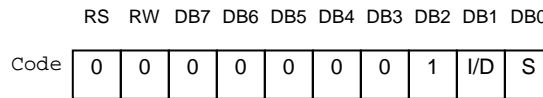

Set the moving direction of cursor and display.

- **I/D : Increment / decrement of DDRAM address (cursor or blink)**  
 When I/D = "High", cursor moves to right and DDRAM address is increased by 1.  
 When I/D = "Low", cursor moves to left and DDRAM address is decreased by 1.  
 \* CGRAM operates the same as DDRAM, when read from or write to CGRAM.
- **S: Shift of entire display**  
 When DDRAM read (CGRAM read/write) operation or S = "Low", shift of entire display is not performed. If S = "High" and DDRAM write operation, shift of entire display is performed according to I/D value (I/D = "1" : shift left, I/D = "0" : shift right).

S	I/D	Description
H	H	Shift the display to the left
H	L	Shift the display to the right

● **Set CGRAM Address**

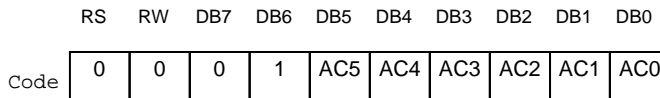

Set CGRAM address to AC.

This instruction makes CGRAM data available from MPU.

● **Set DDRAM Address**

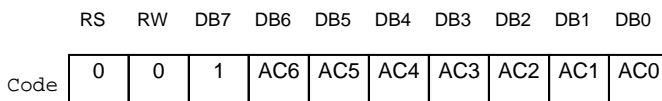

Set DDRAM address to AC.

This instruction makes DDRAM data available from MPU.

When 1-line display mode (N = 0), DDRAM address is from "00H" to "4FH".

In 2-line display mode (N = 1), DDRAM address in the 1st line is from "00H" to "27H", and DDRAM address in the 2nd line is from "40H" to "67H".

## EXT=1

### ● Bias resistor select

RS	RW	DB7	DB6	DB5	DB4	DB3	DB2	DB1	DB0
Code	0	0	0	0	0	0	1	Rb1	Rb0

Set internal bias resistor value.

Rb1	Rb0	Description
L	L	External bias resistor select.
L	H	Build-in resistor select (R=2.2K).
H	L	Build-in resistor select (R=6.8K).
H	H	Build-in resistor select (R=9.0K).

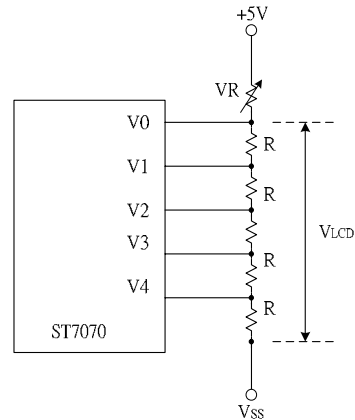

### ● COM, SEG direction select

RS	RW	DB7	DB6	DB5	DB4	DB3	DB2	DB1	DB0	
Code	0	0	0	1	0	0	C1	C2	S1	S2

The SEG and COM output in ST7070 all have bi-direction control by the register.

#### COM OUTPUT :

COM output	C1	COM1	COM8
0	0	COM1 →	Common Address → COM8
1	1	COM8 →	Common Address → COM1

COM output	C2	COM9	COM16
0	0	COM9 →	Common Address → COM16
1	1	COM16 →	Common Address → COM9

#### SEG OUTPUT :

SEG output	S1	SEG1	SEG40
0	0	SEG1 →	Segment Address → SEG40
1	1	SEG40 →	Segment Address → SEG1

SEG output	S2	SEG41	SEG80
0	0	SEG41 →	Segment Address → SEG80
1	1	SEG80 →	Segment Address → SEG41

**Set display data length**

	RS	RW	DB7	DB6	DB5	DB4	DB3	DB2	DB1	DB0
Code	0	0	0	1	L5	L4	L3	L2	L1	L0

L5	L4	L3	L2	L1	L0	Data length
0	0	0	0	0	0	1
0	0	0	0	0	1	2
...	...	...	...	...	...	...
0	0	1	1	1	0	79
0	0	1	1	1	1	80

Only in 3line-SPI interface will use the register to set the number of display data(Max=4F).  
 To write data to DDRAM , send Data Direction Command in 3-pin SPI . Data is latched at the rising edge of SCLK .  
 And the DDRAM column address pointer will be increased by one automatically.

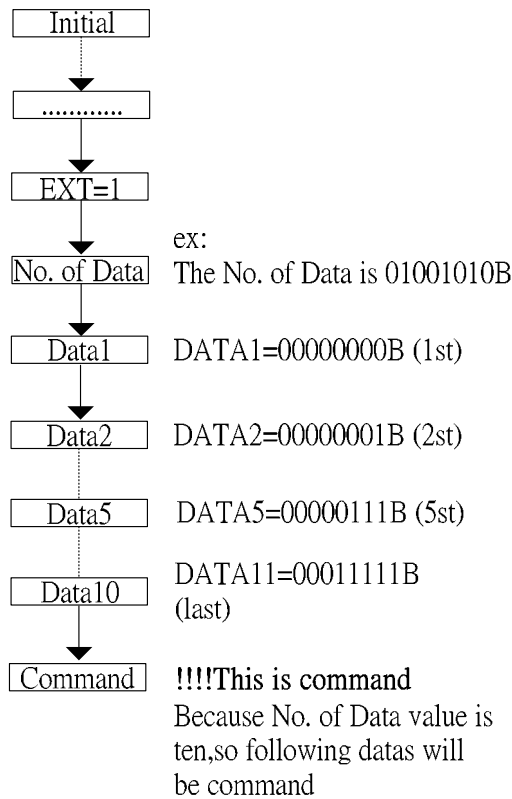
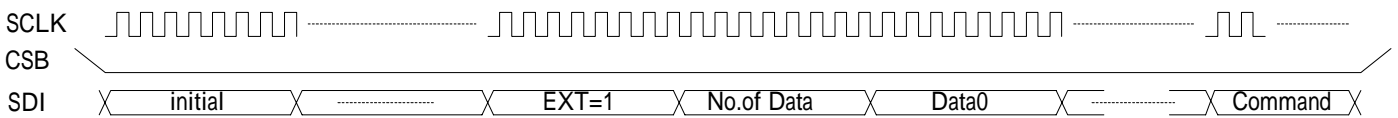

## ■ Reset Function

### Initializing by Internal Reset Circuit

An internal reset circuit automatically initializes the ST7070 when the power is turned on or hardware reset pin has low. The following instructions are executed during the initialization. The busy flag (BF) is kept in the busy state until the initialization ends (BF = 1). The busy state lasts for 40 ms after VCC rises to 4.5 V.

1. Display clear
2. Function set:
  - DL = 1; 8-bit interface data
  - N = 1; 2-line display
  - EXT=0;disable extension instruction.
3. Display on/off control:
  - D = 0; Display off
  - C = 0; Cursor off
  - P = 0; Page 1 of font table(DDRAM data b8=0)
4. Entry mode set:
  - I/D = 1; Increment by 1
  - S = 0; No shift
5. Bias resistor select:
  - Rb1=0;Rb2=0 select external bias resistor.
6. COM、SEG direction select:
  - C1=0;C2=0;S1=0;S2=0 not reverse.

#### Note:

If the electrical characteristics conditions listed under the table Power Supply Conditions Using Internal Reset Circuit are not met, the internal reset circuit will not operate normally and will fail to initialize the ST7070. For such a case, initialization must be performed by the MPU as explain by the following figure.

## ■ Initializing by Instruction

- 8-bit Interface (fosc=270KHz)

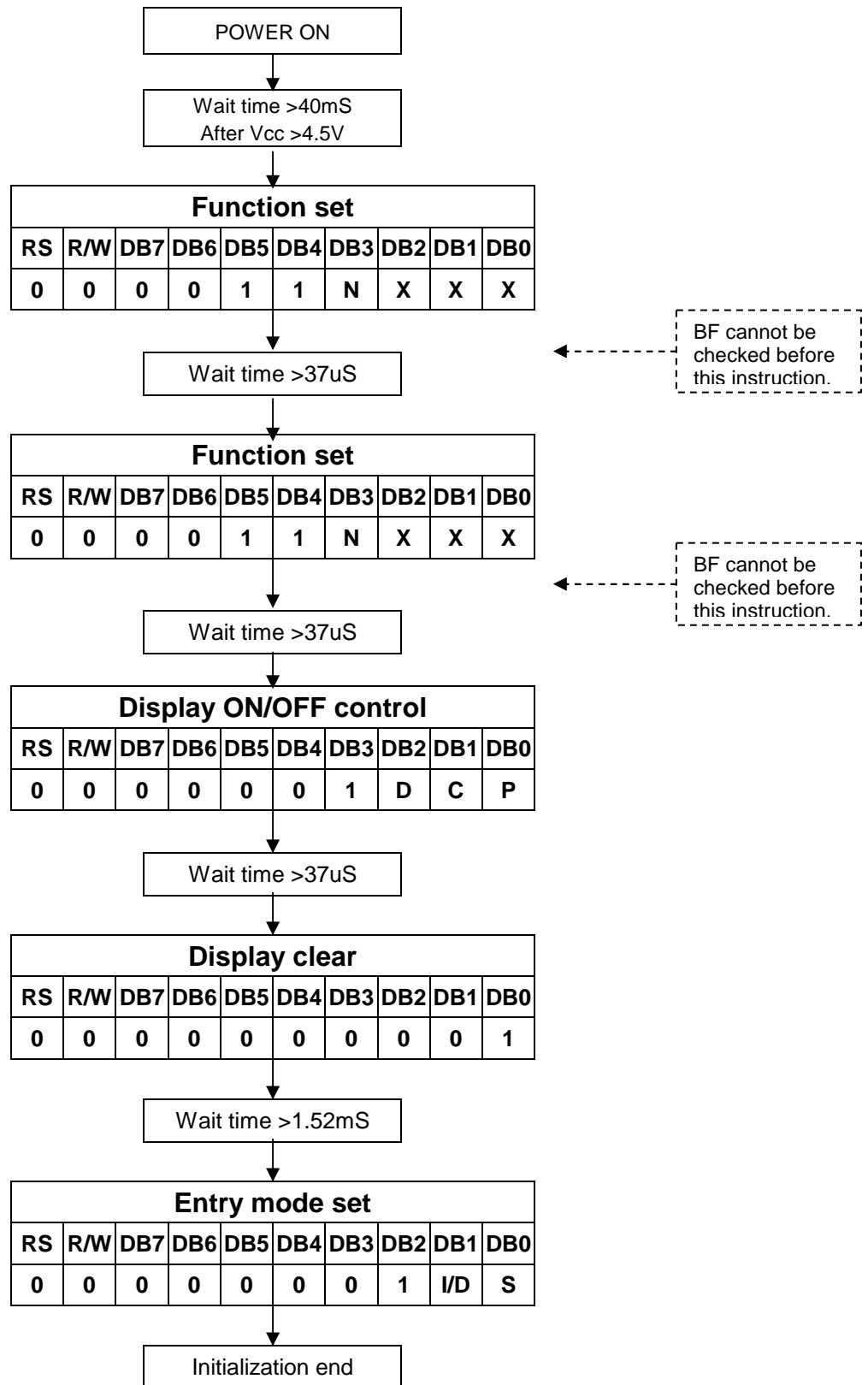



## ➤ Initial Program Code Example For 8051 MPU(8 Bit Interface):

```
-----  
INITIAL_START:  
    CALL    DELAY40mS  
  
    MOV     A,#38H          ;FUNCTION SET  
    CALL    WRINS_NOCHK    ;8 bit,N=1,5*7dot  
    CALL    DELAY37uS  
  
    MOV     A,#38H          ;FUNCTION SET  
    CALL    WRINS_NOCHK    ;8 bit,N=1,5*7dot  
    CALL    DELAY37uS  
  
    MOV     A,#0FH         ;DISPLAY ON  
    CALL    WRINS_CHK  
    CALL    DELAY37uS  
  
    MOV     A,#01H         ;CLEAR DISPLAY  
    CALL    WRINS_CHK  
    CALL    DELAY1.52mS  
  
    MOV     A,#06H         ;ENTRY MODE SET  
    CALL    WRINS_CHK      ;CURSOR MOVES TO RIGHT  
    CALL    DELAY37uS
```

```
-----  
MAIN_START:
```

```
XXXX  
XXXX  
XXXX  
XXXX  
.  
.  
.  
.
```

```
-----  
WRINS_CHK:
```

```
    CALL    CHK_BUSY
```

```
WRINS_NOCHK:
```

```
    CLR     RS              ;EX:Port 3.0  
    CLR     RW              ;EX:Port 3.1  
    SETB    E               ;EX:Port 3.2  
    MOV     P1,A            ;EX:Port 1=Data Bus  
    CLR     E  
    MOV     P1,#FFH        ;For Check Busy Flag  
    RET
```

```
-----  
CHK_BUSY:
```

```
    ;Check Busy Flag
```

```
    CLR     RS  
    SETB    RW  
    SETB    E  
    JB      P1.7,$  
    CLR     E  
    RET
```

● 4-bit Interface (fosc=270KHz)

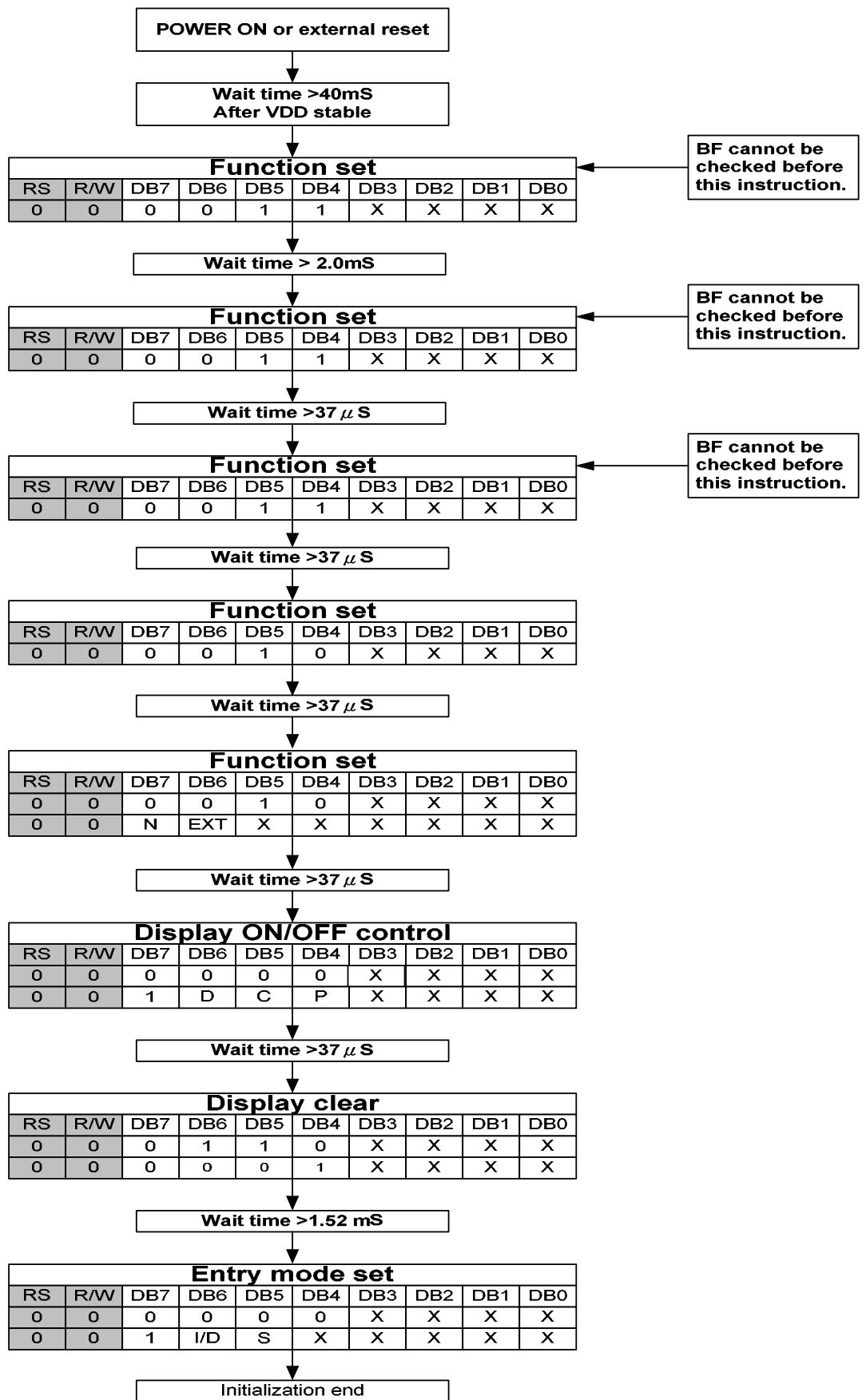



Serial Interface (fosc=270KHz)

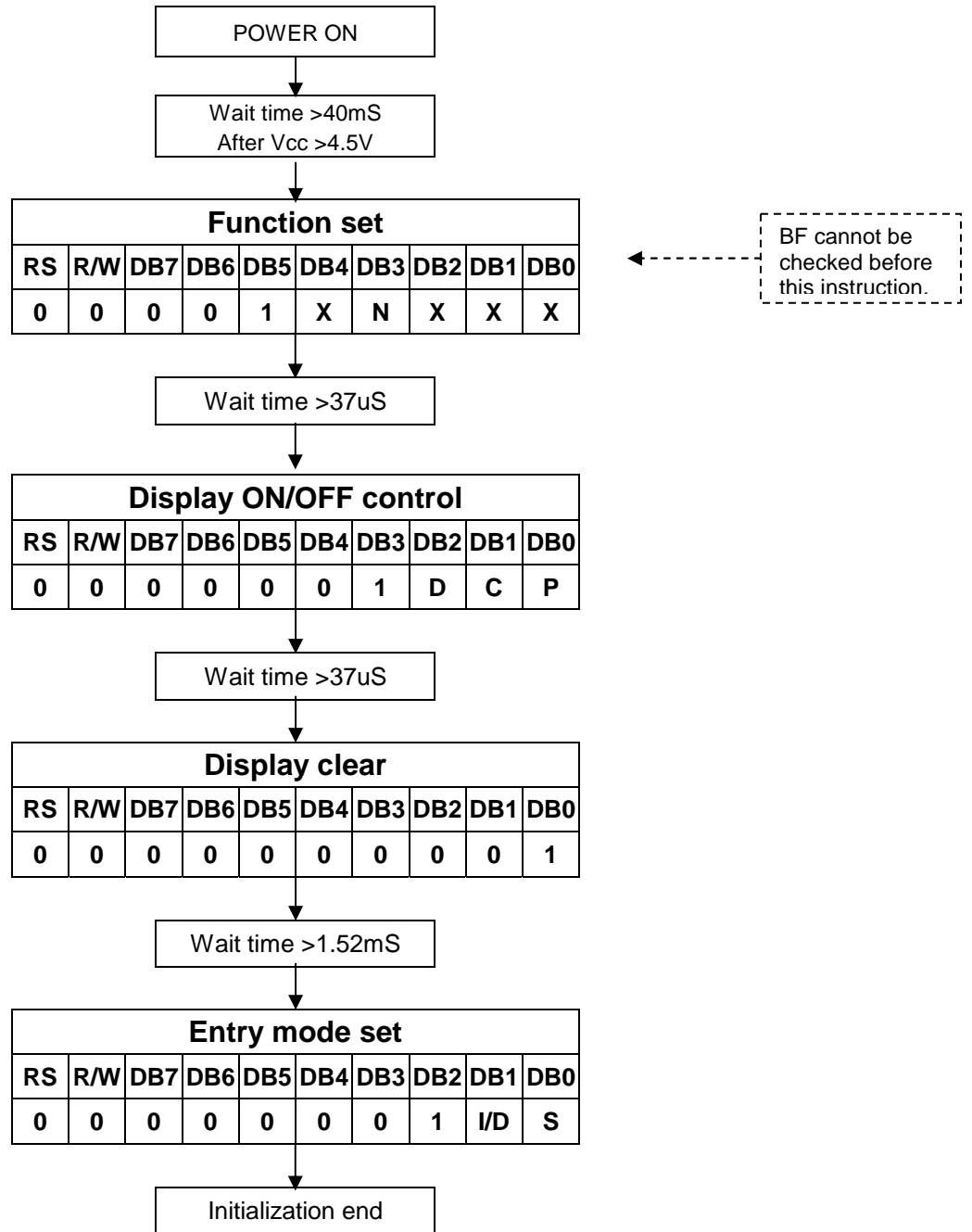

## ■ Interfacing to the MPU

The ST7070 can send data in either two 4-bit operations or one 8-bit operation or serial operation, thus allowing interfacing with 4- or 8-bit or serial MPU.

- **For 4-bit interface data, only four bus lines (DB4 to DB7) are used for transfer.** Bus lines DB0 to DB3 are disabled. The data transfer between the ST7070 and the MPU is completed after the 4-bit data has been transferred twice. As for the order of data transfer, the four high order bits (for 8-bit operation, DB4 to DB7) are transferred before the four low order bits (for 8-bit operation, DB0 to DB3). The busy flag must be checked (one instruction) after the 4-bit data has been transferred twice. Two more 4-bit operations then transfer the busy flag and address counter data.

### ➤ Example of busy flag check timing sequence

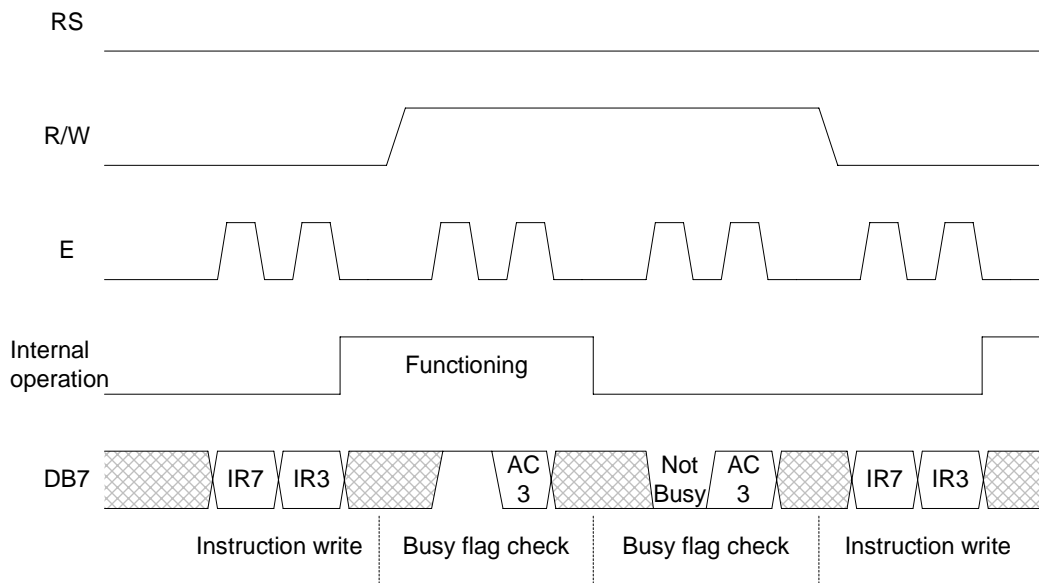

### ➤ Intel 8051 interface

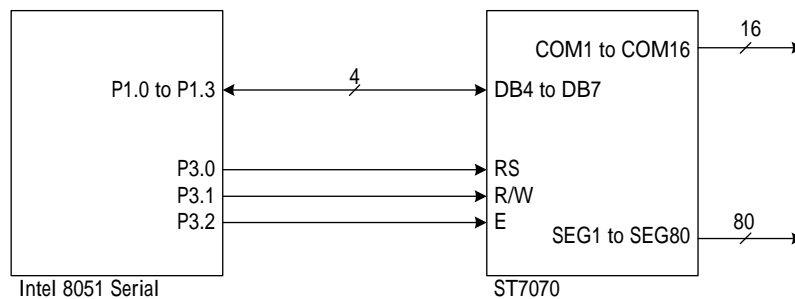

- For 8-bit interface data, all eight bus lines (DB0 to DB7) are used.

➤ Example of busy flag check timing sequence

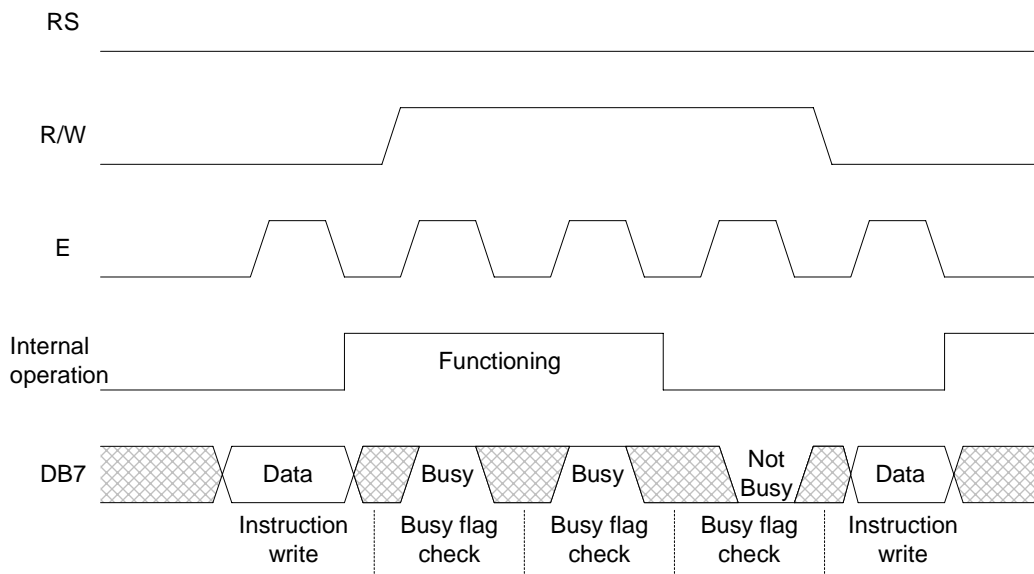

➤ Intel 8051 interface

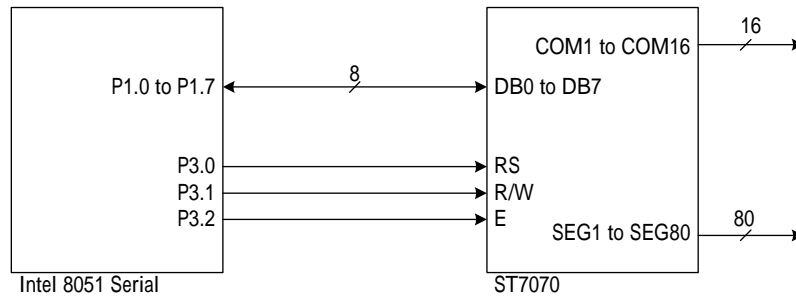

- For serial interface data, bus lines (DB5 to DB7) are used. 4-Pin SPI

➤ Example of timing sequence

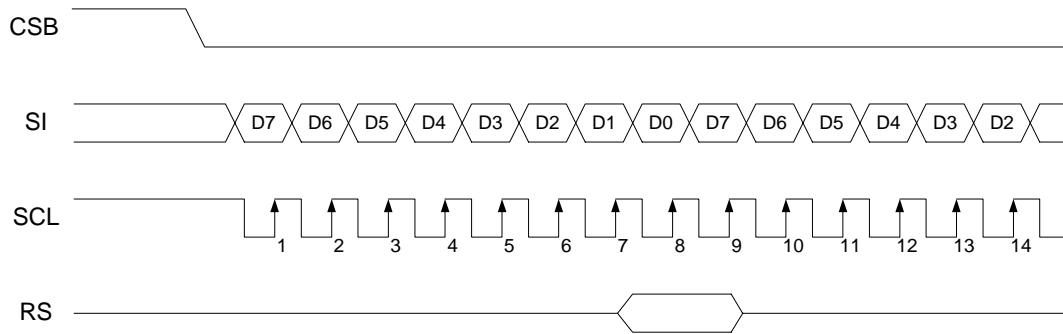

➤ Intel 8051 interface(Serial)

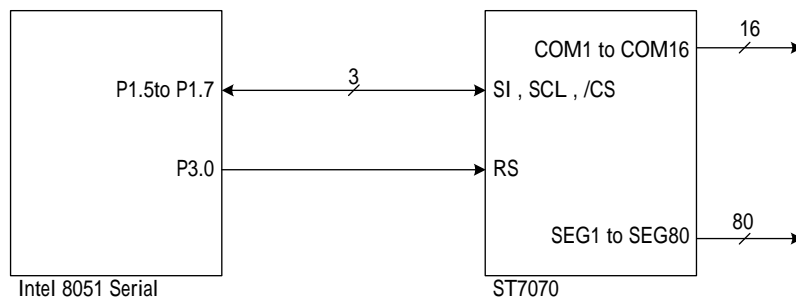

- For serial interface data, bus lines (DB5 to DB7) are used. 3-Pin SPI

➤ Example of timing sequence

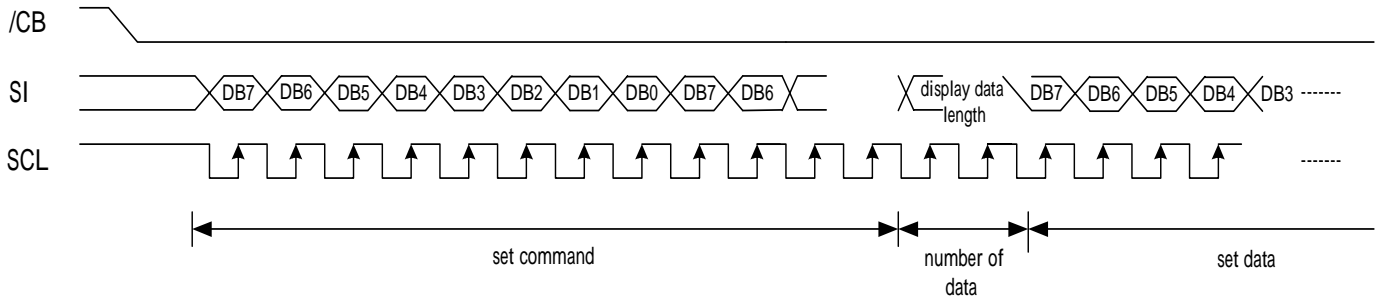

➤ Intel 8051 interface(Serial)

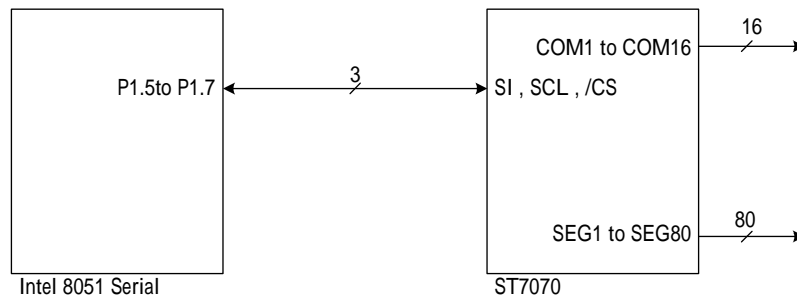



### Supply Voltage for LCD Drive

There are different voltages that supply to ST7070's pin (V0 – V4) to obtain LCD drive waveform. We could use the register command (Ra1,Ra0) to set up the Internal or External Bias Resistor. The relations of the bias, duty factor and supply voltages are shown as below. External Bias Resistor could set up to 1/4 bias and 1/5 bias, but Internal Bias Resistor only could set up to 1/5 bias.

External Resistor	Duty Factor	
	1/8	1/8,1/16
	Bias	
Supply Voltage	1/4	1/5
Bias Resistor Select	Ra1=0,Ra0=0	Ra1=0,Ra0=0
V0	V <sub>LCD</sub>	V <sub>LCD</sub>
V1	3/4V <sub>LCD</sub>	4/5V <sub>LCD</sub>
V2	1/2V <sub>LCD</sub>	3/5V <sub>LCD</sub>
V3	1/2V <sub>LCD</sub>	2/5V <sub>LCD</sub>
V4	1/4V <sub>LCD</sub>	1/5V <sub>LCD</sub>

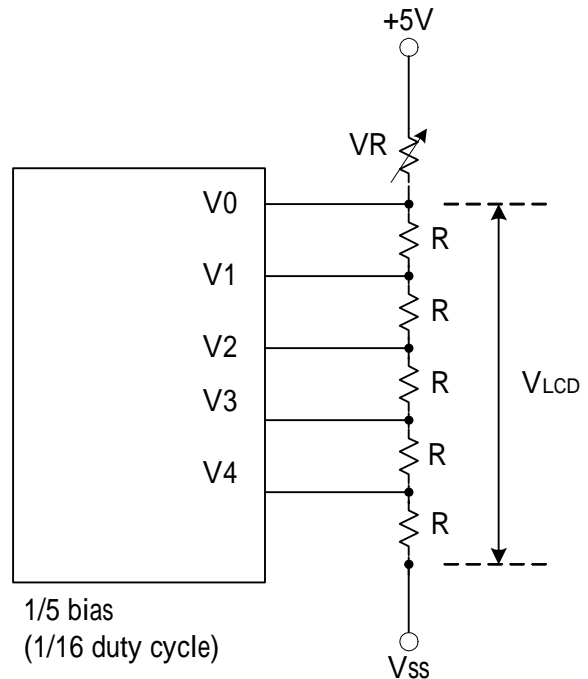
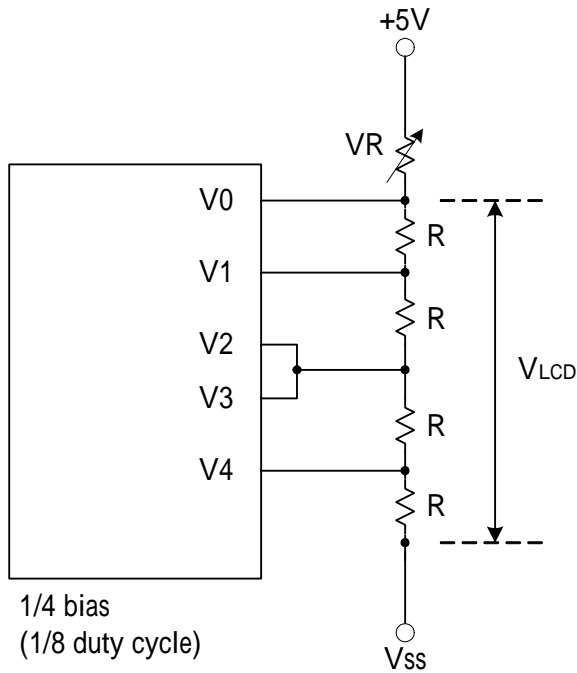

# ST7070

Internal Resistor	Duty Factor		
	1/8 , 1/16		
	Bias		
Supply Voltage	1/5	1/5	1/5
Bias Resistor Select	Ra1=0,Ra0=1	Ra1=1,Ra0=0	Ra1=1,Ra0=1
Internal Resistor	R=2.2K	R=6.8K	R=9.0K
V0	VLCD	VLCD	VLCD
V1	4/5VLCD	4/5VLCD	4/5VLCD
V2	3/5VLCD	3/5VLCD	3/5VLCD
V3	2/5VLCD	2/5VLCD	2/5VLCD
V4	1/5VLCD	1/5VLCD	1/5VLCD

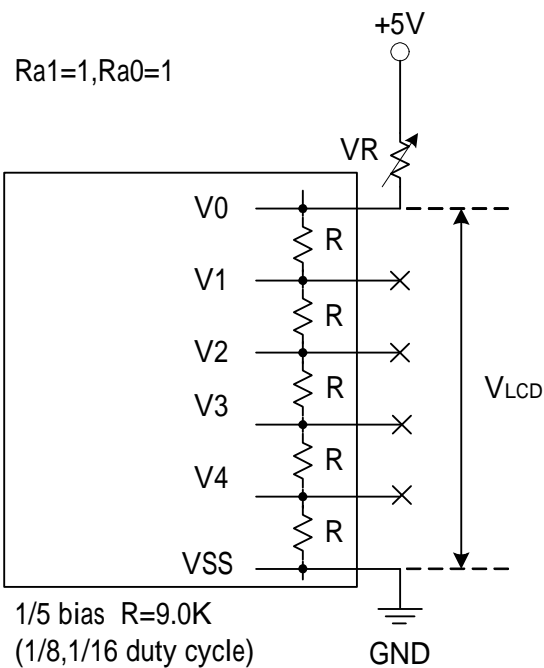
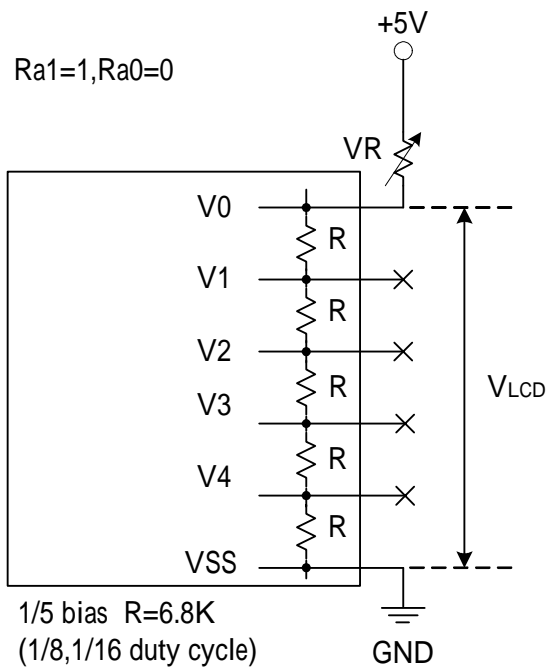
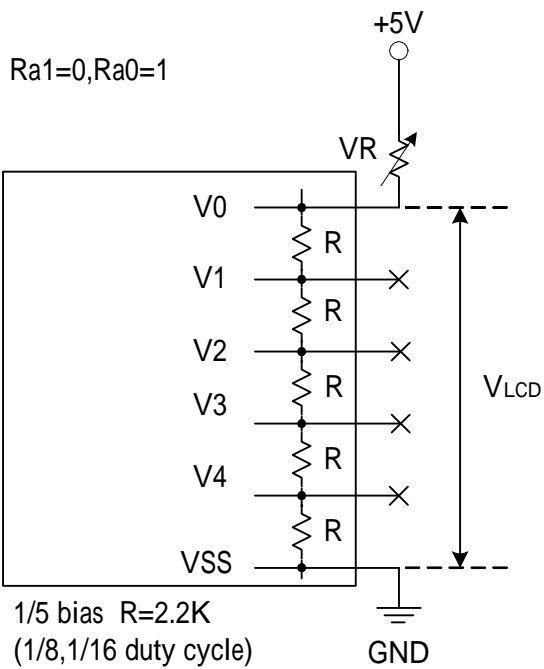

## ■ Timing Characteristics

- Writing data from MPU to ST7070

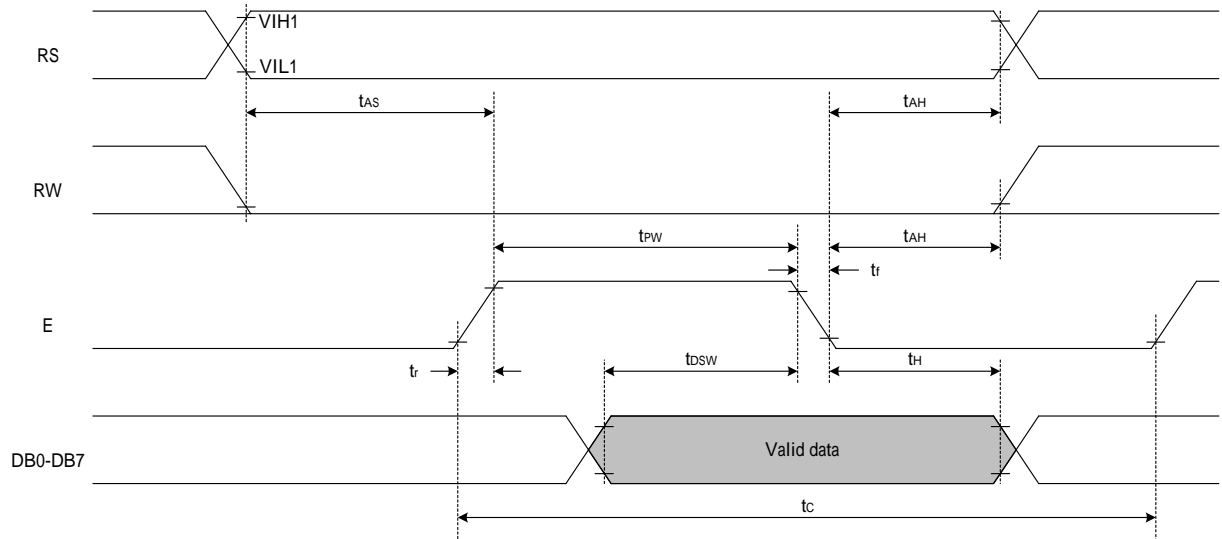

- Reading data from ST7070 to MPU

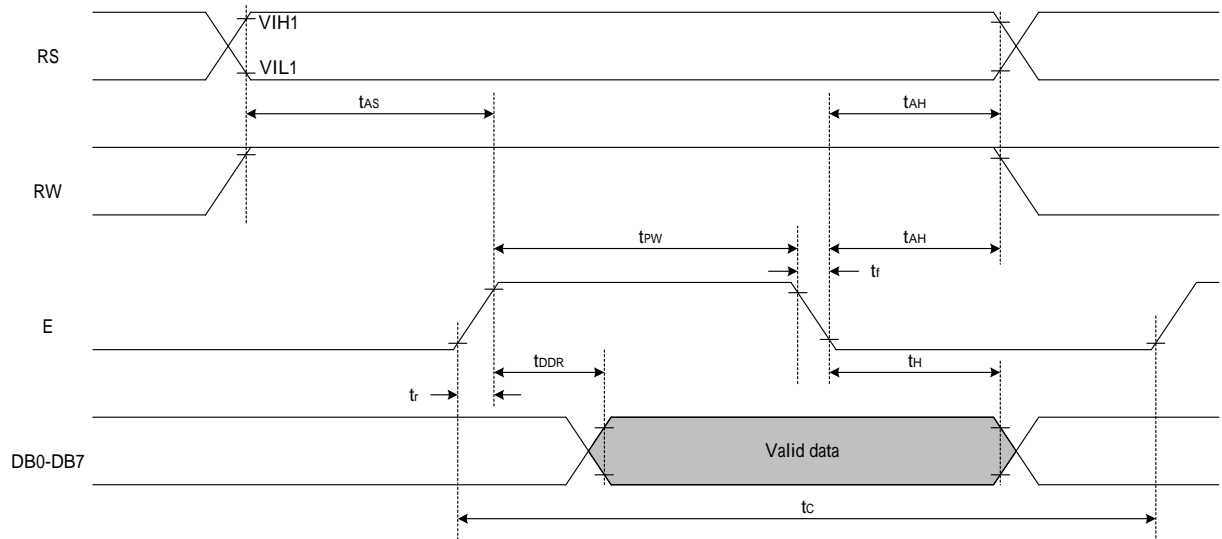

● Interface Timing with External Driver

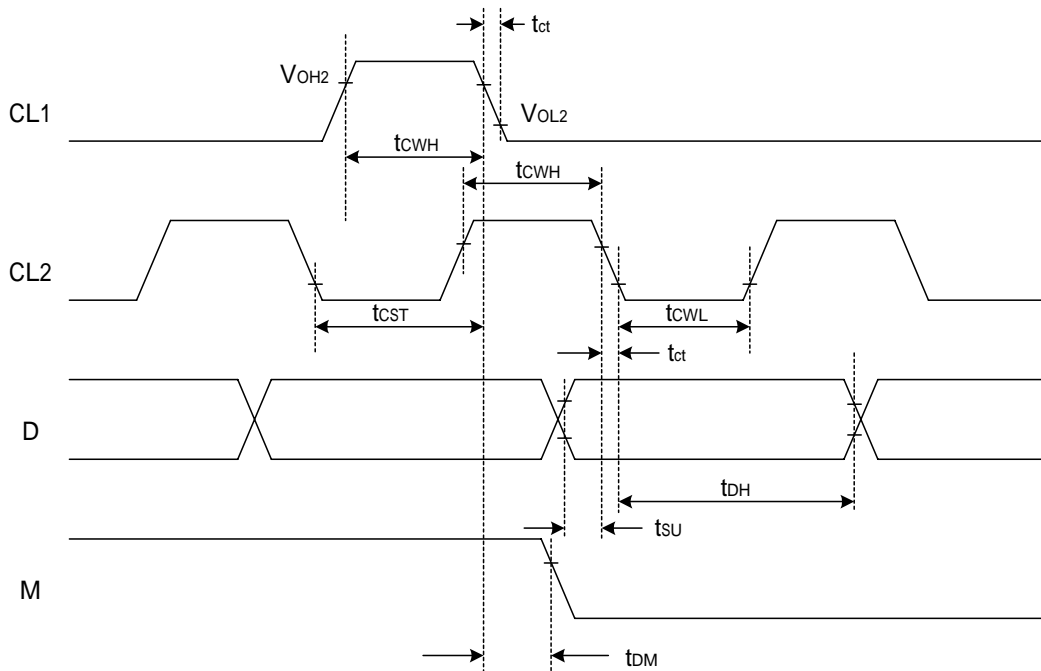

● Internal Power Supply Reset

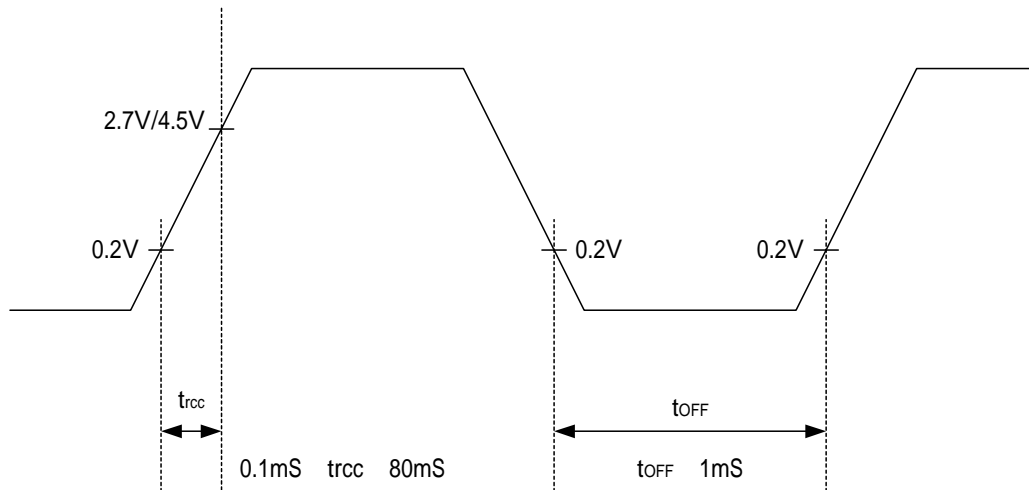

Notes:

- $t_{off}$  compensates for the power oscillation period caused by momentary power supply oscillations.
- Specified at 4.5V for 5V operation, and at 2.7V for 3V operation.
- For if 4.5V is not reached during 5V operation, the internal reset circuit will not operate normally.

## ■ AC Characteristics

In 6800 interface

(TA = 25 , VCC = 2.7V )

Symbol	Characteristics	Test Condition	Min.	Typ.	Max.	Unit
<i>Internal Clock Operation</i>						
f <sub>OSC</sub>	OSC Frequency	R = 75KΩ	190	270	350	KHz
<i>External Clock Operation</i>						
f <sub>EX</sub>	External Frequency	-	125	270	410	KHz
	Duty Cycle	-	45	50	55	%
T <sub>R</sub> , T <sub>F</sub>	Rise/Fall Time	-	-	-	0.2	μs
<i>Write Mode (Writing data from MPU to ST7070)</i>						
T <sub>C</sub>	Enable Cycle Time	Pin E (except clear display)	40	-	-	us
T <sub>PW</sub>	Enable Pulse Width	Pin E	40	-	-	ns
T <sub>R</sub> , T <sub>F</sub>	Enable Rise/Fall Time	Pin E	-	-	25	ns
T <sub>AS</sub>	Address Setup Time	Pins: RS,RW,E	0	-	-	ns
T <sub>AH</sub>	Address Hold Time	Pins: RS,RW,E	10	-	-	ns
T <sub>DSW</sub>	Data Setup Time	Pins: DB0 - DB7	20	-	-	ns
T <sub>H</sub>	Data Hold Time	Pins: DB0 - DB7	10	-	-	ns
<i>Read Mode (Reading Data from ST7070 to MPU)</i>						
T <sub>C</sub>	Enable Cycle Time	Pin E	1200	-	-	ns
T <sub>PW</sub>	Enable Pulse Width	Pin E	480	-	-	ns
T <sub>R</sub> , T <sub>F</sub>	Enable Rise/Fall Time	Pin E	-	-	25	ns
T <sub>AS</sub>	Address Setup Time	Pins: RS,RW,E	0	-	-	ns
T <sub>AH</sub>	Address Hold Time	Pins: RS,RW,E	10	-	-	ns
T <sub>DDR</sub>	Data Setup Time	Pins: DB0 - DB7	-	-	320	ns
T <sub>H</sub>	Data Hold Time	Pins: DB0 - DB7	10	-	-	ns
<i>Interface Mode with LCD Driver(ST7921)</i>						
T <sub>CWH</sub>	Clock Pulse with High	Pins: CL1, CL2	800	-	-	ns
T <sub>CWL</sub>	Clock Pulse with Low	Pins: CL1, CL2	800	-	-	ns
T <sub>CST</sub>	Clock Setup Time	Pins: CL1, CL2	500	-	-	ns
T <sub>SU</sub>	Data Setup Time	Pin: D	300	-	-	ns
T <sub>DH</sub>	Data Hold Time	Pin: D	300	-	-	ns
T <sub>DM</sub>	M Delay Time	Pin: M	0	-	2000	ns

## ■ AC Characteristics

In 6800 interface

(TA = 25 , VCC = 5V)

Symbol	Characteristics	Test Condition	Min.	Typ.	Max.	Unit
<i>Internal Clock Operation</i>						
f <sub>OSC</sub>	OSC Frequency	R = 91KΩ	190	270	350	KHz
<i>External Clock Operation</i>						
f <sub>EX</sub>	External Frequency	-	125	270	410	KHz
	Duty Cycle	-	45	50	55	%
T <sub>R</sub> , T <sub>F</sub>	Rise/Fall Time	-	-	-	0.2	μs
<i>Write Mode (Writing data from MPU to ST7070)</i>						
T <sub>C</sub>	Enable Cycle Time	Pin E (except clear display)	40	-	-	us
T <sub>PW</sub>	Enable Pulse Width	Pin E	40	-	-	ns
T <sub>R</sub> , T <sub>F</sub>	Enable Rise/Fall Time	Pin E	-	-	25	ns
T <sub>AS</sub>	Address Setup Time	Pins: RS, RW, E	0	-	-	ns
T <sub>AH</sub>	Address Hold Time	Pins: RS, RW, E	10	-	-	ns
T <sub>DSW</sub>	Data Setup Time	Pins: DB0 - DB7	20	-	-	ns
T <sub>H</sub>	Data Hold Time	Pins: DB0 - DB7	10	-	-	ns
<i>Read Mode (Reading Data from ST7070 to MPU)</i>						
T <sub>C</sub>	Enable Cycle Time	Pin E	1200	-	-	ns
T <sub>PW</sub>	Enable Pulse Width	Pin E	140	-	-	ns
T <sub>R</sub> , T <sub>F</sub>	Enable Rise/Fall Time	Pin E	-	-	25	ns
T <sub>AS</sub>	Address Setup Time	Pins: RS, RW, E	0	-	-	ns
T <sub>AH</sub>	Address Hold Time	Pins: RS, RW, E	10	-	-	ns
T <sub>DDR</sub>	Data Setup Time	Pins: DB0 - DB7	-	-	100	ns
T <sub>H</sub>	Data Hold Time	Pins: DB0 - DB7	10	-	-	ns
<i>Interface Mode with LCD Driver(ST7921)</i>						
T <sub>CWH</sub>	Clock Pulse with High	Pins: CL1, CL2	800	-	-	ns
T <sub>CWL</sub>	Clock Pulse with Low	Pins: CL1, CL2	800	-	-	ns
T <sub>CST</sub>	Clock Setup Time	Pins: CL1, CL2	500	-	-	ns
T <sub>SU</sub>	Data Setup Time	Pin: D	300	-	-	ns
T <sub>DH</sub>	Data Hold Time	Pin: D	300	-	-	ns
T <sub>DM</sub>	M Delay Time	Pin: M	0	-	2000	ns

## ■ AC Characteristics

In Serial interface

(TA = 25 , VCC = 2.7V )

Symbol	Characteristics	Test Condition	Min.	Typ.	Max.	Unit
<i>Internal Clock Operation</i>						
f <sub>OSC</sub>	OSC Frequency	R = 75KΩ	190	270	350	KHz
<i>External Clock Operation</i>						
f <sub>EX</sub>	External Frequency	-	125	270	410	KHz
	Duty Cycle	-	45	50	55	%
T <sub>R</sub> , T <sub>F</sub>	Rise/Fall Time	-	-	-	0.2	μs
<i>Write Mode (Writing data from MPU to ST7070)</i>						
T <sub>C</sub>	Enable Cycle Time	Pin E	2000	-	-	ns
T <sub>PW</sub>	Enable Pulse Width	Pin E	950	-	-	ns
T <sub>R</sub> , T <sub>F</sub>	Enable Rise/Fall Time	Pin E	-	-	25	ns
T <sub>AS</sub>	Address Setup Time	Pins: RS,E	50	-	-	ns
T <sub>AH</sub>	Address Hold Time	Pins: RS,,E	10	-	-	ns
T <sub>DSW</sub>	Data Setup Time	Pins: DB0 - DB7	10	-	-	ns
T <sub>H</sub>	Data Hold Time	Pins: DB0 - DB7	50	-	-	ns
<i>Interface Mode with LCD Driver(ST7921)</i>						
T <sub>CWH</sub>	Clock Pulse with High	Pins: CL1, CL2	800	-	-	ns
T <sub>CWL</sub>	Clock Pulse with Low	Pins: CL1, CL2	800	-	-	ns
T <sub>CST</sub>	Clock Setup Time	Pins: CL1, CL2	500	-	-	ns
T <sub>SU</sub>	Data Setup Time	Pin: D	300	-	-	ns
T <sub>DH</sub>	Data Hold Time	Pin: D	300	-	-	ns
T <sub>DM</sub>	M Delay Time	Pin: M	0	-	2000	ns

## ■ AC Characteristics

In Serial Interface

(TA = 25 °C, VCC = 5V)

Symbol	Characteristics	Test Condition	Min.	Typ.	Max.	Unit
<i>Internal Clock Operation</i>						
f <sub>OSC</sub>	OSC Frequency	R = 91KΩ	190	270	350	KHz
<i>External Clock Operation</i>						
f <sub>EX</sub>	External Frequency	-	125	270	410	KHz
	Duty Cycle	-	45	50	55	%
T <sub>R</sub> , T <sub>F</sub>	Rise/Fall Time	-	-	-	0.2	μs
<i>Write Mode (Writing data from MPU to ST7070)</i>						
T <sub>C</sub>	Enable Cycle Time	Pin E	800	-	-	ns
T <sub>PW</sub>	Enable Pulse Width	Pin E	40	-	-	ns
T <sub>R</sub> , T <sub>F</sub>	Enable Rise/Fall Time	Pin E	-	-	25	ns
T <sub>AS</sub>	Address Setup Time	Pins: RS,E	50	-	-	ns
T <sub>AH</sub>	Address Hold Time	Pins: RS,E	10	-	-	ns
T <sub>DSW</sub>	Data Setup Time	Pins: DB0 - DB7	10	-	-	ns
T <sub>H</sub>	Data Hold Time	Pins: DB0 - DB7	50	-	-	ns
<i>Interface Mode with LCD Driver(ST7921)</i>						
T <sub>CWH</sub>	Clock Pulse with High	Pins: CL1, CL2	800	-	-	ns
T <sub>CWL</sub>	Clock Pulse with Low	Pins: CL1, CL2	800	-	-	ns
T <sub>CST</sub>	Clock Setup Time	Pins: CL1, CL2	500	-	-	ns
T <sub>SU</sub>	Data Setup Time	Pin: D	300	-	-	ns
T <sub>DH</sub>	Data Hold Time	Pin: D	300	-	-	ns
T <sub>DM</sub>	M Delay Time	Pin: M	0	-	2000	ns



## ■ Absolute Maximum Ratings

Characteristics	Symbol	Value
Power Supply Voltage	$V_{CC}$	-0.3 to +5.5
LCD Driver Voltage	$V_{LCD}$	$V_{SS}+7.0$ to $V_{SS}-0.3$
Input Voltage	$V_{IN}$	-0.3 to $V_{CC}+0.3$
Operating Temperature	$T_A$	-40°C to + 90°C
Storage Temperature	$T_{STO}$	-55°C to + 125°C

## ■ DC Characteristics

(  $T_A = 25$  ,  $V_{CC} = 2.7 V - 4.5 V$  )

Symbol	Characteristics	Test Condition	Min.	Typ.	Max.	Unit
$V_{CC}$	Operating Voltage	-	2.7	-	4.5	V
$V_{LCD}$	LCD Voltage	$V_0 - V_{SS}$	3.0	-	7.0	V
$I_{CC}$	Power Supply Current	$f_{OSC} = 270KHz$ $V_{CC}=3.0V$	-	0.1	0.25	mA
$V_{IH1}$	Input High Voltage (Except OSC1)	-	0.7V <sub>CC</sub>	-	$V_{CC}$	V
$V_{IL1}$	Input Low Voltage (Except OSC1)	-	- 0.3	-	0.6	V
$V_{IH2}$	Input High Voltage (OSC1)	-	0.7V <sub>CC</sub>	-	$V_{CC}$	V
$V_{IL2}$	Input Low Voltage (OSC1)	-	-	-	0.2V <sub>CC</sub>	V
$V_{OH1}$	Output High Voltage (DB0 - DB7)	$I_{OH} = -0.1mA$	0.75 V <sub>CC</sub>	-	-	V
$V_{OL1}$	Output Low Voltage (DB0 - DB7)	$I_{OL} = 0.1mA$	-	-	0.2V <sub>CC</sub>	V
$V_{OH2}$	Output High Voltage (Except DB0 - DB7)	$I_{OH} = -0.04mA$	0.8V <sub>CC</sub>	-	$V_{CC}$	V
$V_{OL2}$	Output Low Voltage (Except DB0 - DB7)	$I_{OL} = 0.04mA$	-	-	0.2V <sub>CC</sub>	V
$R_{COM}$	Common Resistance	$V_{LCD} = 4V, I_d = 0.05mA$	-	2	20	K $\Omega$
$R_{SEG}$	Segment Resistance	$V_{LCD} = 4V, I_d = 0.05mA$	-	2	30	K $\Omega$
$I_{LEAK}$	Input Leakage Current	$V_{IN} = 0V$ to $V_{CC}$	-1	-	1	$\mu A$
$I_{PUP}$	Pull Up MOS Current	$V_{CC} = 3V$	10	60	120	$\mu A$

NOTE : External bias resistor select , so I<sub>dd</sub> doesn't include the follower current.

## ■ DC Characteristics

(  $T_A = 25$  ,  $V_{CC} = 4.5\text{ V} - 5.5\text{ V}$  )

Symbol	Characteristics	Test Condition	Min.	Typ.	Max.	Unit
$V_{CC}$	Operating Voltage	-	4.5	-	5.5	V
$V_{LCD}$	LCD Voltage	$V_0 - V_{SS}$	3.0	-	7.0	V
$I_{CC}$	Power Supply Current	$f_{OSC} = 270\text{KHz}$ $V_{CC} = 5.0\text{V}$	-	0.2	0.5	mA
$V_{IH1}$	Input High Voltage (Except OSC1)	-	2.5	-	$V_{CC}$	V
$V_{IL1}$	Input Low Voltage (Except OSC1)	-	-0.3	-	0.6	V
$V_{IH2}$	Input High Voltage (OSC1)	-	$V_{CC} - 1$	-	$V_{CC}$	V
$V_{IL2}$	Input Low Voltage (OSC1)	-	-	-	1.0	V
$V_{OH1}$	Output High Voltage (DB0 - DB7)	$I_{OH} = -0.1\text{mA}$	3.9	-	$V_{CC}$	V
$V_{OL1}$	Output Low Voltage (DB0 - DB7)	$I_{OL} = 0.1\text{mA}$	-	-	0.4	V
$V_{OH2}$	Output High Voltage (Except DB0 - DB7)	$I_{OH} = -0.04\text{mA}$	$0.9V_{CC}$	-	$V_{CC}$	V
$V_{OL2}$	Output Low Voltage (Except DB0 - DB7)	$I_{OL} = 0.04\text{mA}$	-	-	$0.1V_{CC}$	V
$R_{COM}$	Common Resistance	$V_{LCD} = 4\text{V}$ , $I_d = 0.05\text{mA}$	-	2	20	$\text{K}\Omega$
$R_{SEG}$	Segment Resistance	$V_{LCD} = 4\text{V}$ , $I_d = 0.05\text{mA}$	-	2	30	$\text{K}\Omega$
$I_{LEAK}$	Input Leakage Current	$V_{IN} = 0\text{V to } V_{CC}$	-1	-	1	$\mu\text{A}$
$I_{PUP}$	Pull Up MOS Current	$V_{CC} = 5\text{V}$	90	200	330	$\mu\text{A}$

NOTE : External bias resistor select , so  $I_{DD}$  doesn't include the follower current.

## ■ LCD Frame Frequency

- Assume the oscillation frequency is 270KHZ, 1 clock cycle time = 3.7us, 1/16 duty; 1/5 bias, 1 frame = 3.7us x 200 x 16 = 11840us=11.8ms(84.7Hz)

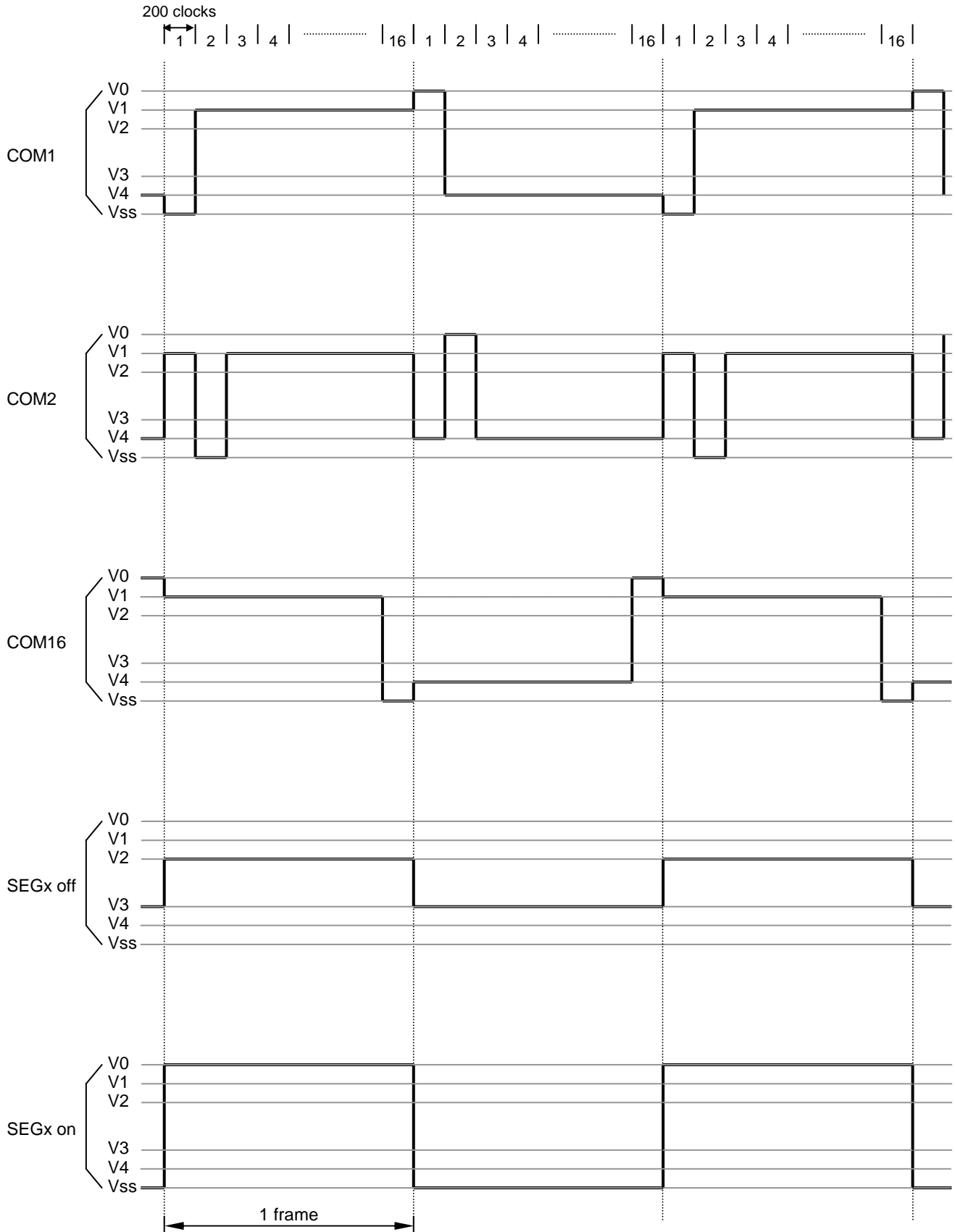

- Assume the oscillation frequency is 270KHZ, 1 clock cycle time = 3.7us, 1/8 duty; 1/4 bias,1 frame = 3.7us x 400 x 8 = 11840us=11.8ms (84.7Hz)

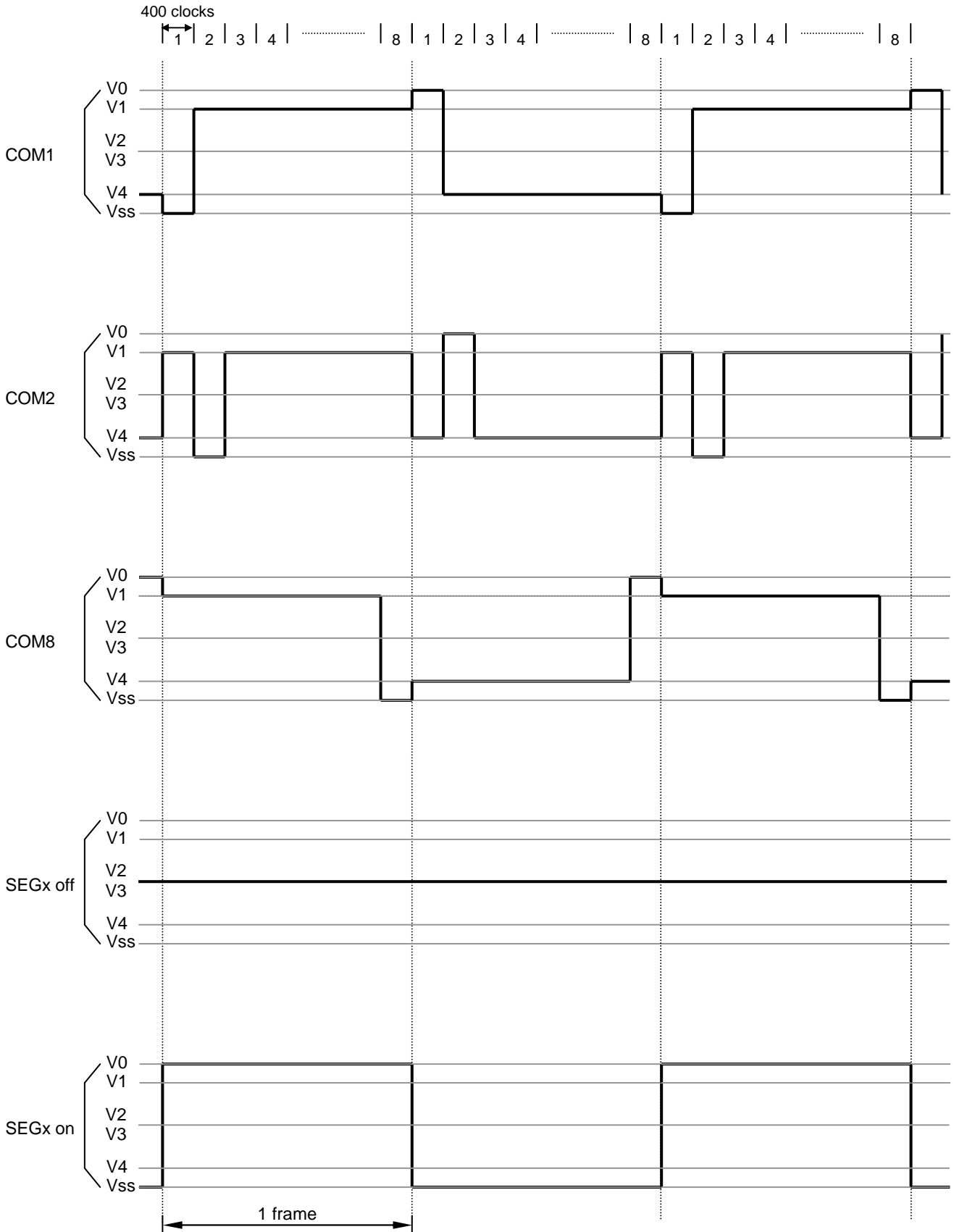

## I/O Pad Configuration

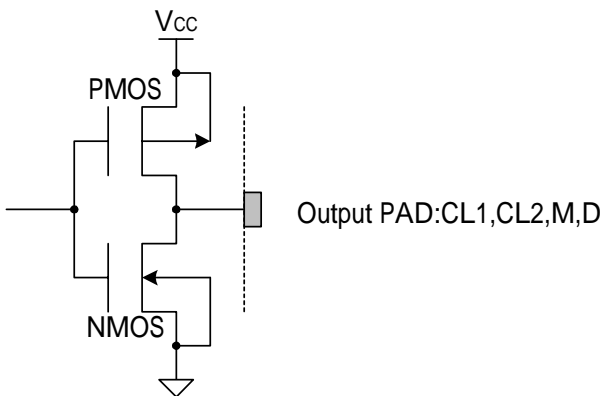
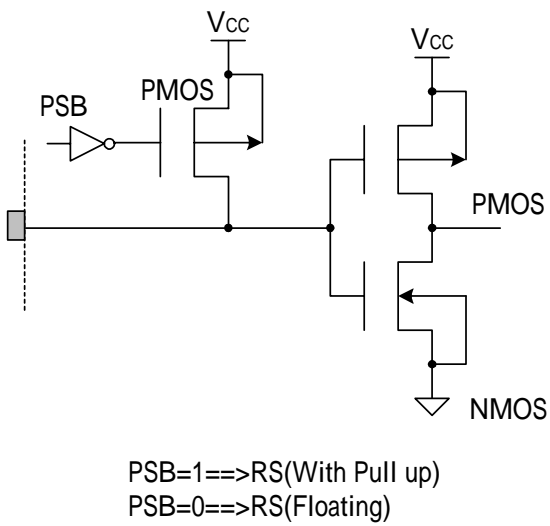
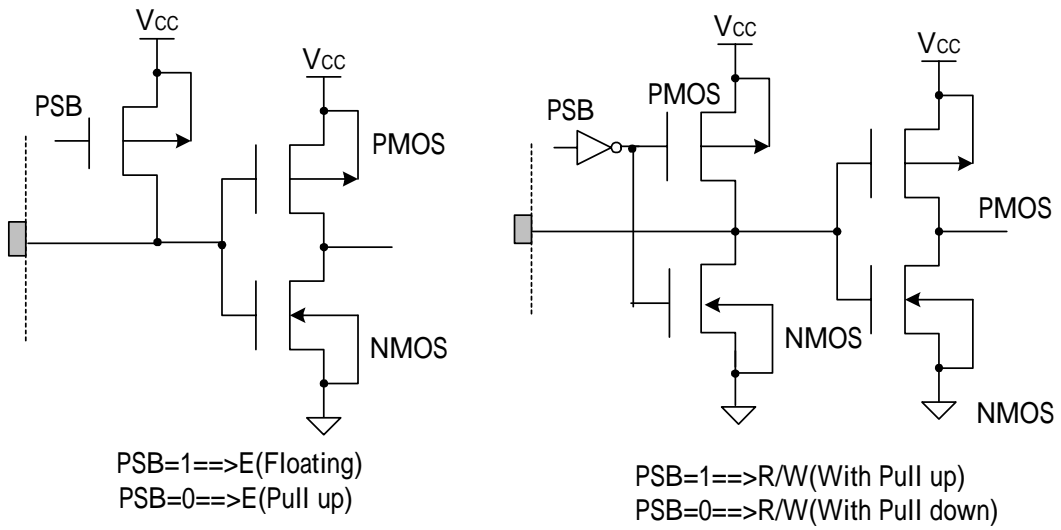

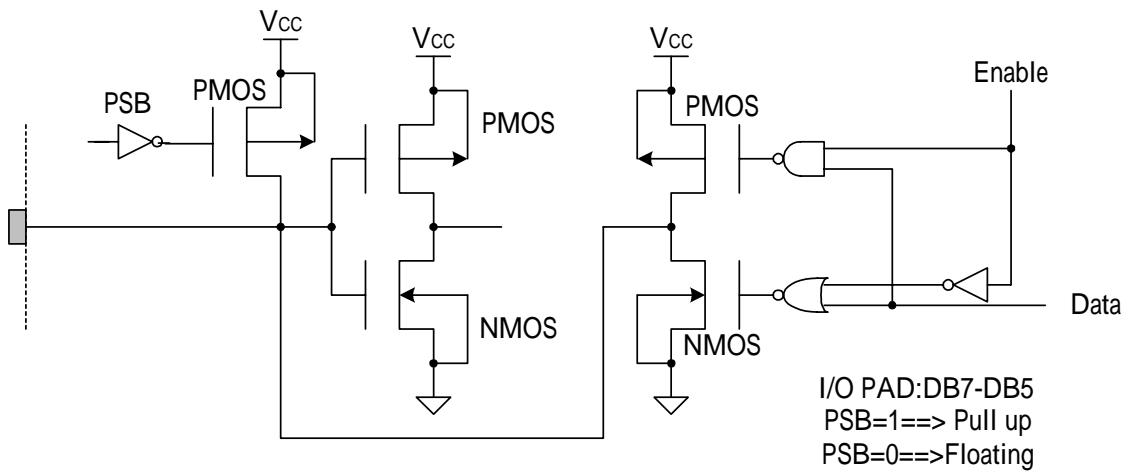
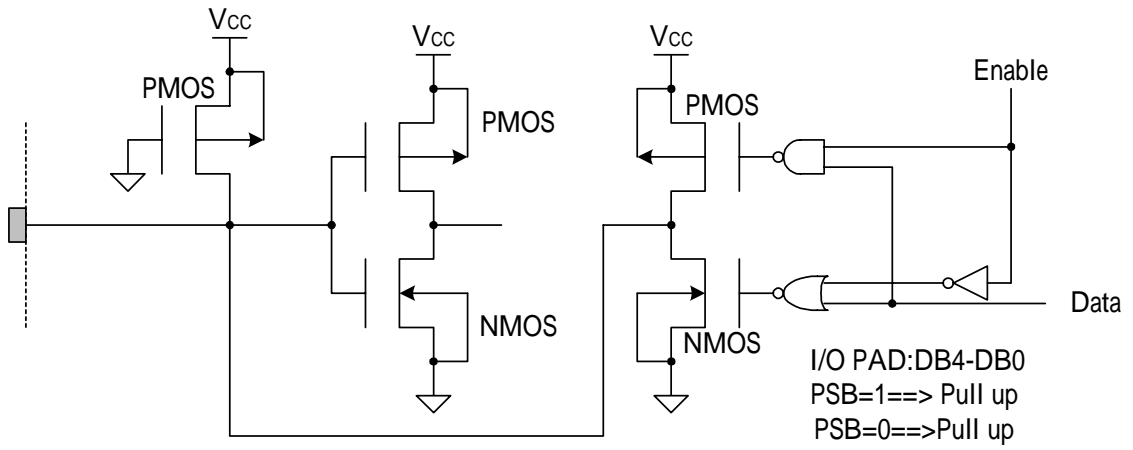

## ■ LCD and ST7070 Connection

1. 5x8 dots, 16 characters x 1 line (1/4 bias, 1/8 duty)

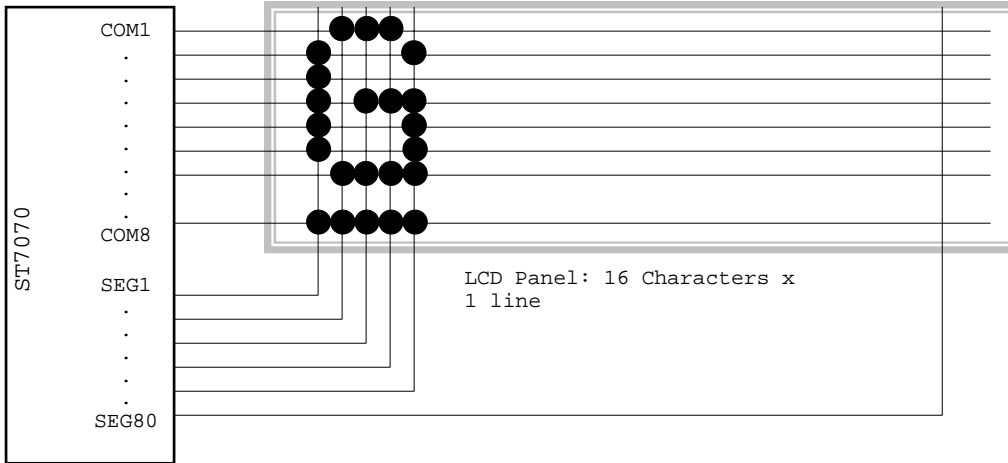

2. 5x8 dots, 16 characters x 2 line (1/5 bias, 1/16 duty)

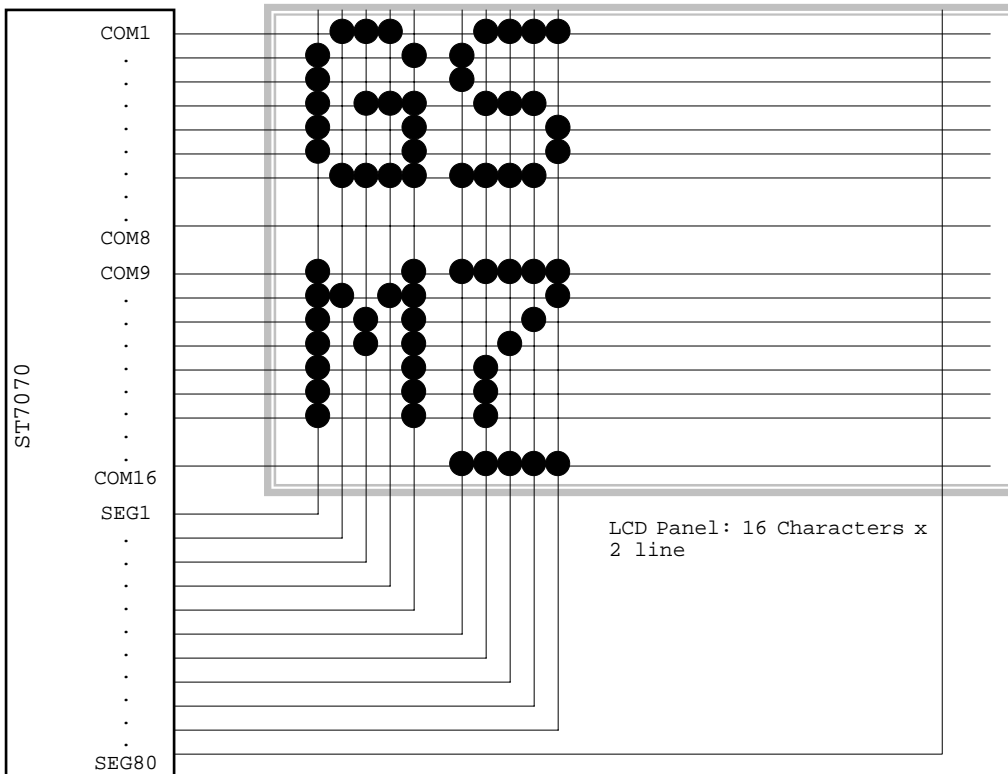

3. 5x8 dots, 32 characters x 1 line (1/5 bias, 1/16 duty)

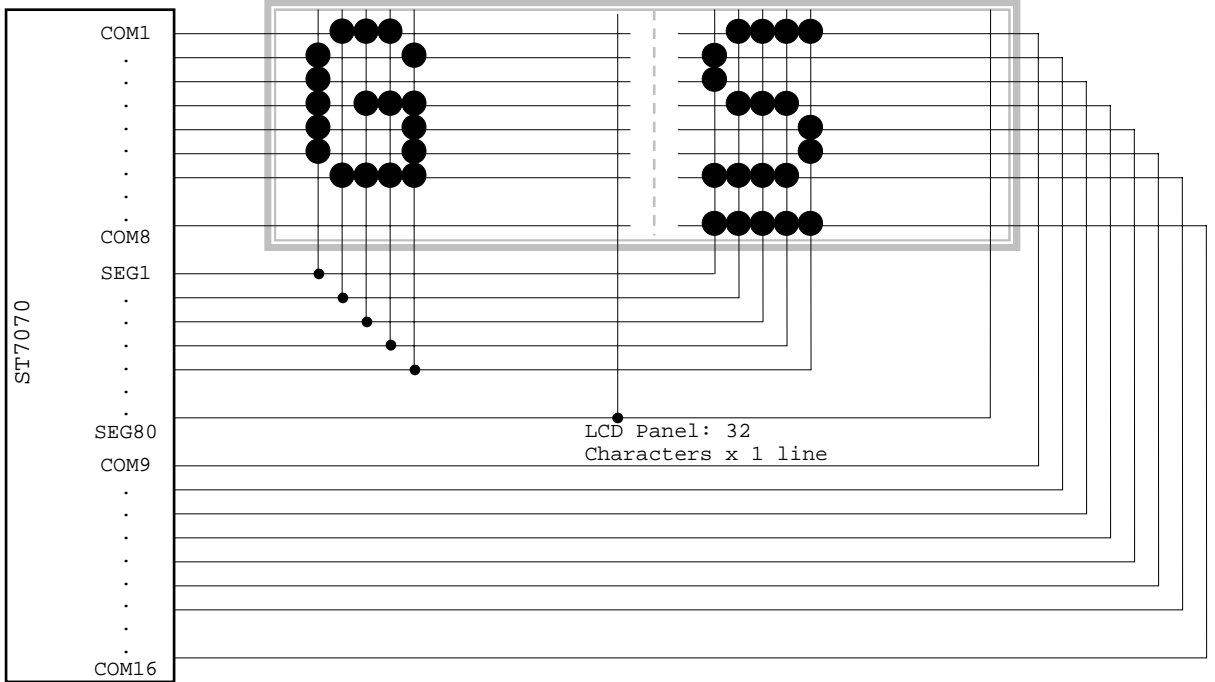



Application Circuit

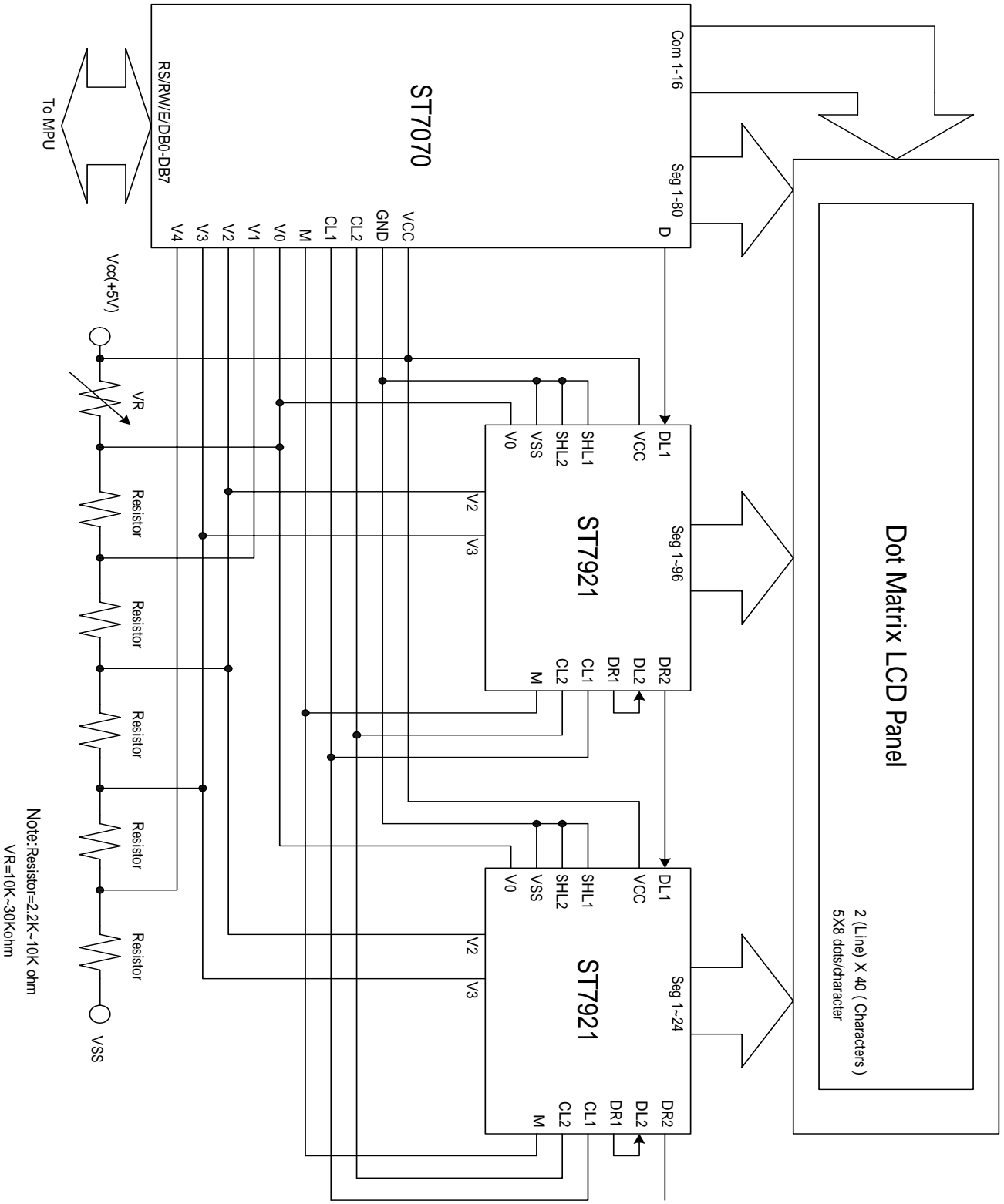

Note: Resistor=2.2K~10K ohm  
VR=10K~30Kohm

## THE MPU INTERFACE

The ST7070 Series can be connected to 6800 Series MPUs. Moreover, using the serial interface it is possible to operate the ST7070 series chips with fewer signal lines.

The display area can be enlarged by using multiple ST7070 Series chips. When this is done, the chip select signal can be used to select the individual Ics to access.

(1) 6800 8 bits Series MPUs

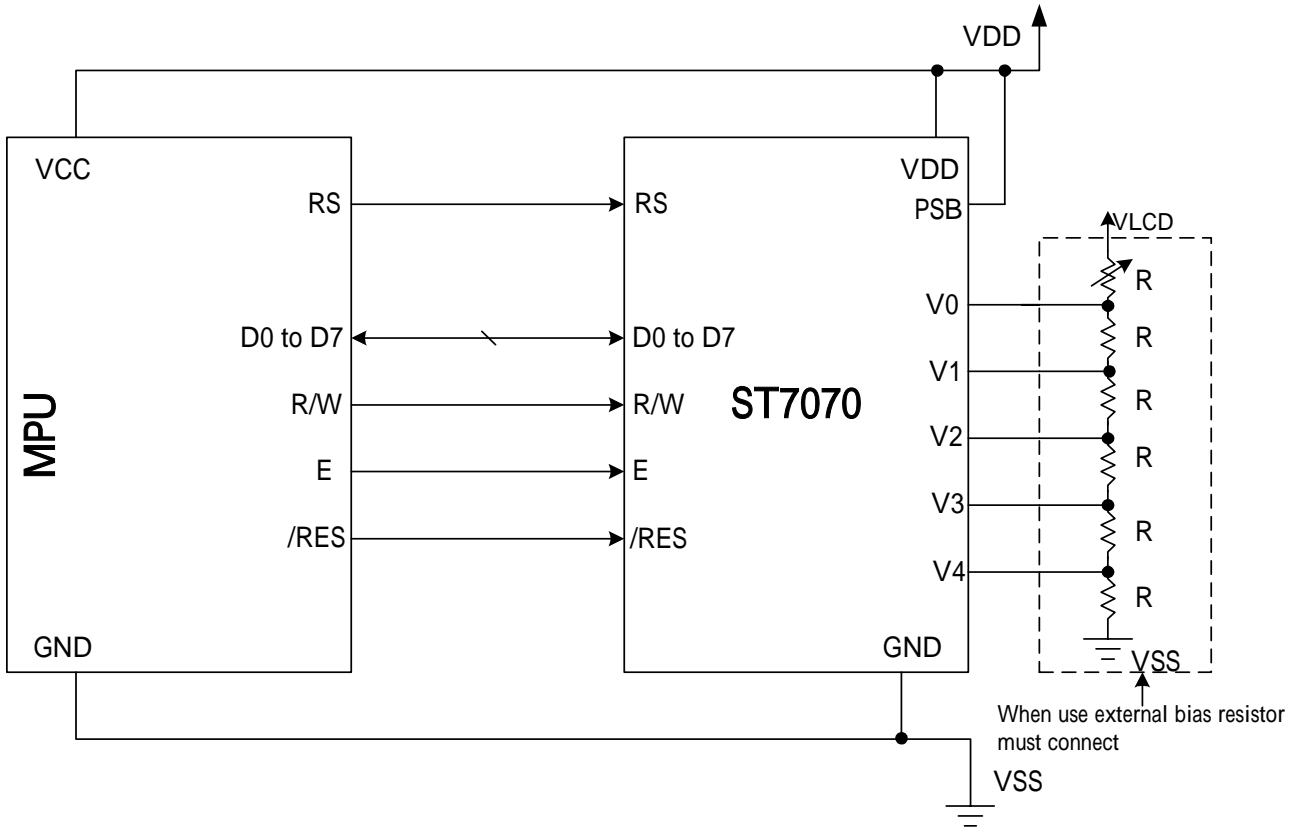

(2) 6800 4 bits Series MPUs

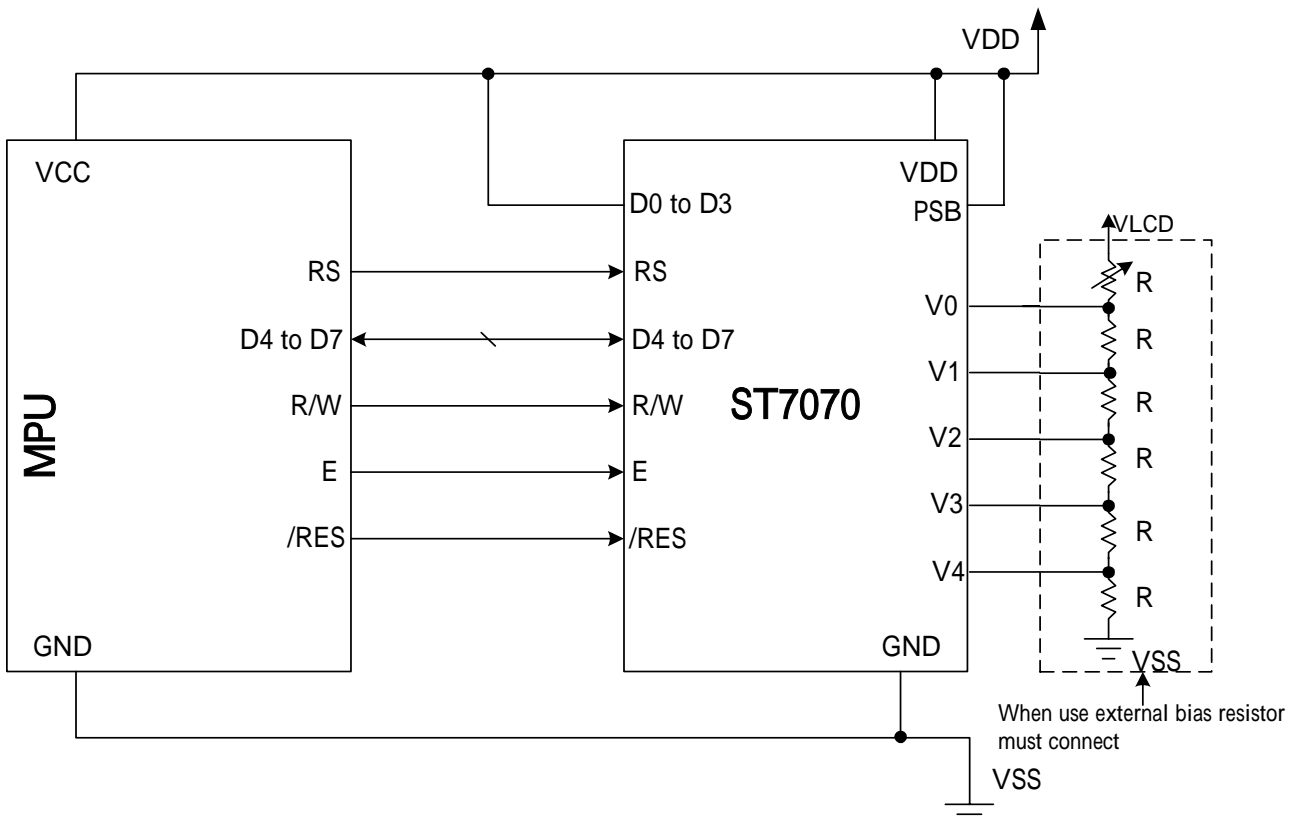

# ST7070

## (3) Using the Serial Interface—For 4 SPI

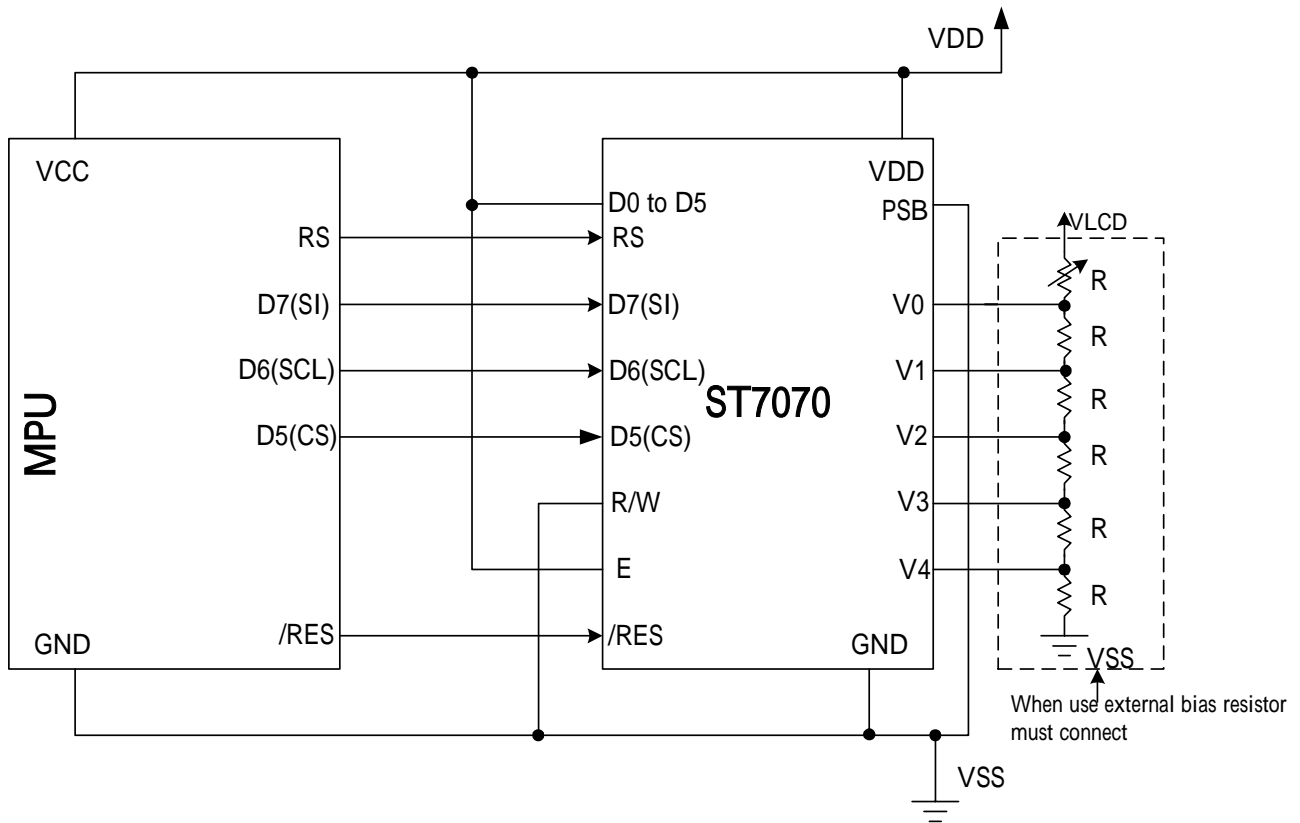

## (4) Using the Serial Interface—For 3 SPI

